

Pre-wired Harness for Gibson[®] Les Paul[®] with Push-Pull Pots

Follow these steps to wire up your guitar

Push-pots: the easy way to split a humbucker

With this wiring, you can switch back and forth between the power of humbuckers and the clarity of single-coils by pushing/pulling your tone control pots.

The pickup series link connects to the push-pull switch, so pulling up creates a coil split for single-coil operation.

STEP 1 Install the switch

Remove the switch from the template. Thread the 3 braided wires through the body rout in your guitar and into the control cavity. Place the switch in its cavity and tighten the mounting nut. A bit of tape will keep the toggle switch plate from turning as you tighten the nut.

STEP 2 Connect the red shielded wire

Find the braided wire that is marked with red magic marker on the end. Solder the braid to the back of the Neck Volume Pot, and solder the inner lead wire to the middle lug of the same pot.

STEP 3 Connect the black shielded wire

The braided wire marked with black is for the Bridge Volume control. Solder the braid to the back of the Bridge Volume Pot and the inner lead to the middle lug of the same pot.

STEP 4 Connect the jack

The remaining braided wire will connect the output jack. Separate the braid. Solder it to the sleeve of the jack. Solder the inner core to the tip.

STEP 5 Connect the pickups

Solder the neck pickup's ground wire to the back of the Neck Volume Pot (see wiring diagram). Solder the hot lead to the lug indicated on the same pot.

Solder the bridge pickup's ground and hot leads to the Bridge Volume Pot as indicated in the diagram.

STEP 6 Connect the series links

Connect the series link of each pickup to the corresponding push-pull pots.

STEP 7 Ground to bridge

The string ground on a Les Paul is made by connecting a ground wire from the tone pot to the metal stud or bushing of the Tune-O-Matic bridge.

If you're replacing existing wiring, the ground wire should be already connected to the bridge mounting stud. Reconnect this wire to the back of your tone pot. If you're installing this harness in a new build, we have included an extra length of ground wire for this connection.

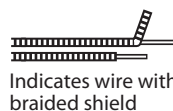
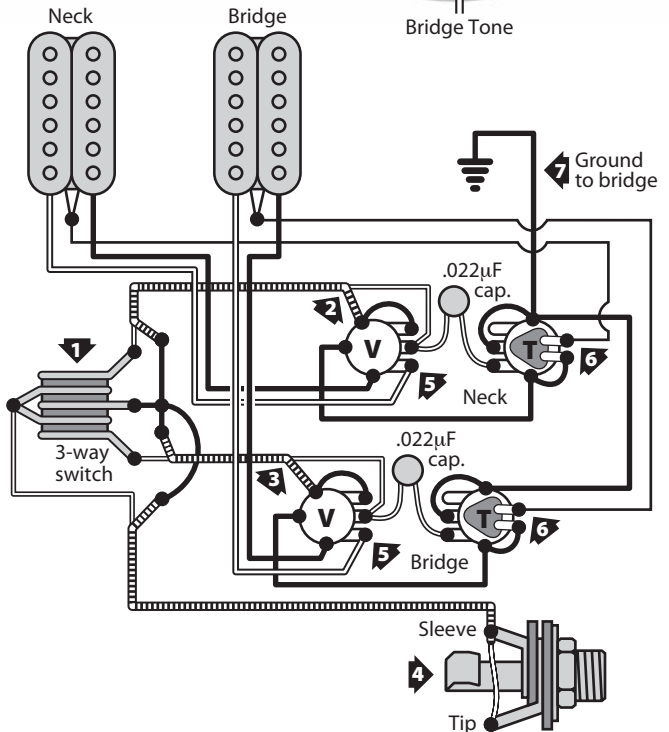
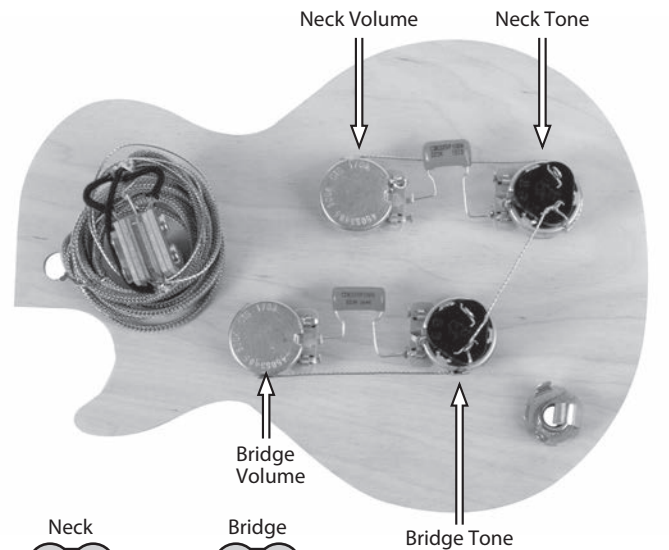

For '50s wiring, connect the caps as shown above.
For modern wiring, connect caps this way:

