

StewMac®

# Monarch

## CLASSIC PEDAL KIT



Kit case is unpainted

IN COLLABORATION WITH  
**EarthQuaker Devices™**

### Assembly Instructions

The **Monarch Overdrive** is an all discrete, FET-based dirt machine. It's designed around the input stage of a vintage amp but configured to produce higher gains that sound very open and free of unnatural compression. The Monarch gives big bottom end with a snappy, bright top at all gain ranges with some careful tuning of the treble and bass controls. The treble and bass controls function as frequency boosters, not the traditional roll off filters in most overdrives. They are located in the preamp section and have a large impact on the over all tone, nature and distortion characteristics. If you are looking for an overdrive for big fat chords with excellent low end retention, this is it!

Easy instructions!  
Clear pictures show where  
each part goes.



RARE / VINTAGE / HARD TO GET  
**WHEN YOU CAN'T BUY IT BUILD IT**

An EarthQuaker Devices original, the **Monarch Overdrive** has been out of production for some time, but now you can build your own!

## Tools and supplies

---

Required: Soldering iron with fine point tip  
Solder  
Wire cutter/stripper  
3/8" nut driver or socket  
1/2" nut driver or socket  
10mm nut driver or socket  
14mm wrench  
#1 Phillips screwdriver

Also helpful: Clear silicone adhesive  
Circuit card holder  
Magnifying glass or OptiVISOR  
StewMac Soldering Aids

Power: This pedal requires a standard 9V DC center-negative power supply or 9V battery (neither included) and consumes less than 100mA.

## Tips for soldering

---

The solder joints you'll make on the circuit board are very small, and too much heat can damage the board. The idea is to make joints quickly, without scorching the eyelets.

Hold components in place for soldering by threading the leads through the board and bending them apart on the reverse side.

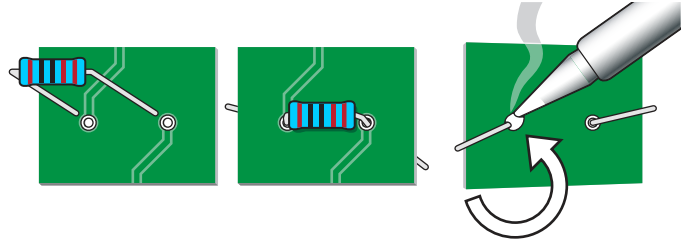

Make your solder joints on the reverse side. Insert the tip into the eyelet and let it heat for 4-5 seconds before touching it with solder. This heats the contact enough for the solder to flow nicely without damage. You don't need much solder, just enough to fill the eyelet. After soldering, trim away the excess lead wire.

## Give your pedal a custom paint job!

---

Any paint sold for use on metal will work well on the kit case. Spray paints like Rustoleum® or Krylon® are a durable finish. You might want to paint the case before building the kit, so you won't need to take the parts back out for painting.

A way to add custom graphics is to print them from your computer onto waterslide decal paper. If you use decals, protect them from scratches by spraying clear topcoats over them.



## Parts list

Resistor values are indicated by colored bands, read from left to right. The first color in the code is usually the one painted closest to a lead wire. When a gold or silver band is present, it's always one of the last colors in the code. A magnifier is a big help in reading these codes.

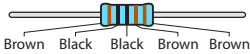

1K $\Omega$  resistor (1) #7357

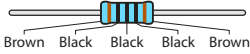

100 $\Omega$  resistor (1) #7352

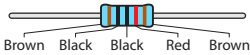

10K $\Omega$  resistors (4) #7362

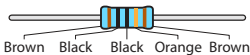

100K $\Omega$  resistor (3) #7365

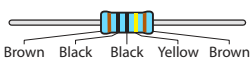

1M $\Omega$  resistors (3) #7367

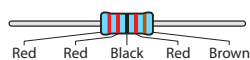

22K $\Omega$  resistors (2) #7379

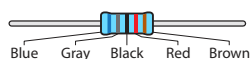

68K $\Omega$  resistor (1) #7380

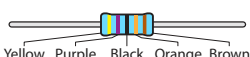

470K $\Omega$  resistor (1) #7382



330 $\Omega$  resistor (1) #7375



10M resistors (2) #7383



1N4001 rectifier diode (1) #7404

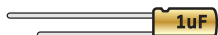

1 $\mu$ F capacitors (2) #7337



10 $\mu$ F capacitors (2) #7338



100 $\mu$ F capacitor (1) #7339

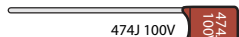

.47 $\mu$ F capacitor (1) #7336

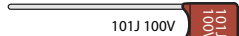

100pF capacitors (2) #7326

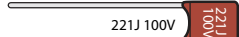

220pF capacitor (1) #7327

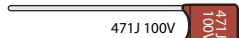

470pF capacitor (1) #7328

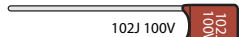

.001 $\mu$ F capacitors (2) #7329

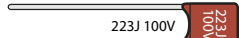

.022 $\mu$ F capacitor (1) #7332

Save time: sort the components by type before you start!

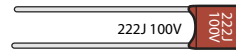
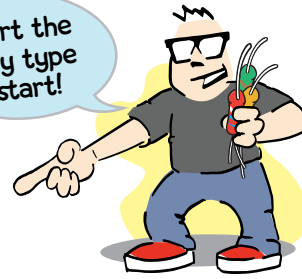

.0022 $\mu$ F capacitor (1) #7330

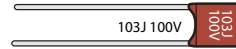

.01 $\mu$ F capacitors (2) #7331

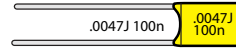

.0047 $\mu$ F capacitor (1) #7321



5mm white LED (1) #7422



5mm LED mounting bezel (1) #7432



BS170 transistor (1) #7485



2N5457 transistors (3) #7486



24" of lead wire (1) #5960

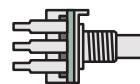

A1M $\Omega$  audio taper pots (3) #7459

B100K $\Omega$  linear taper pot (1) #7453



Adhesive foam tape squares (4) #7560

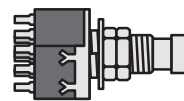

3PDT latching footswitch (1) #1611



1/4" stereo jack (1) #4653

1/4" mono jack (1) #4652



2.1mm DC power connector (1) #7467

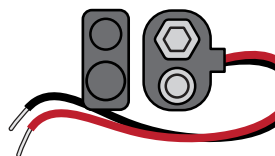

9V battery clip (1) #1222

Protective cap (1) #1227



Control knobs (4) #7501

(Not pictured) Circuit board (1)

(Not pictured) Metal case with 4 screws (1) #7601

## Step 1: Install nineteen resistors

As you get started, note that the values of each component are printed in their proper location on the circuit board unless otherwise noted.

Resistors have a low profile, sitting closer to the board than taller components, so install them first. Their locations are marked on the board with the value of the part.

Resistors are not polarized, so it doesn't matter which lead goes in which eyelet. They can be installed in either direction.

Larger resistors may need to be placed on the board at an angle due to their size.

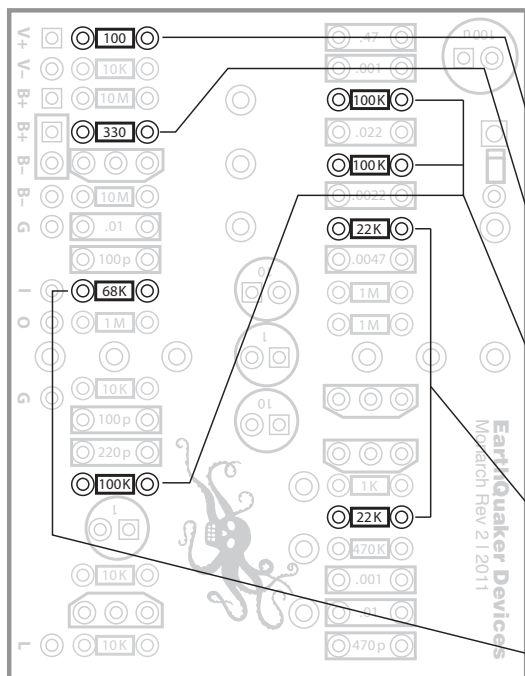
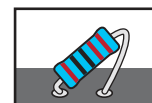

100Ω resistor (1) #7352

330Ω resistor (1) #7375

100KΩ resistors (3) #7365

22KΩ resistors (2) #7379

68KΩ resistor (1) #7380

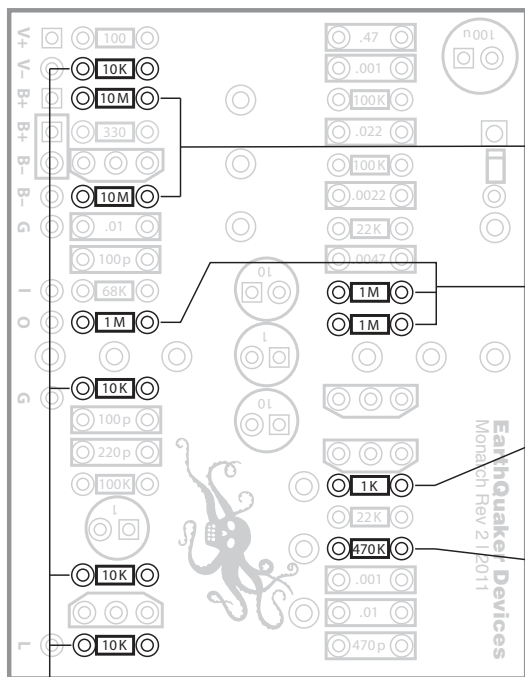

10MΩ resistors (2) #7383

1MΩ resistors (3) #7367

1KΩ resistor (1) #7357

470KΩ resistor (1) #7382

10KΩ resistors (4) #7362

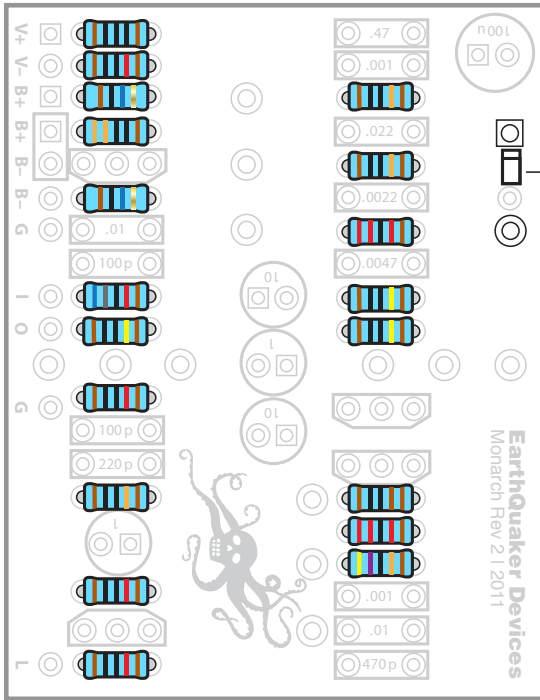

### Step 2: Install one diode



1N4001 rectifier diode (1) #7404  
 Either round eyelet can be used here



Diodes are polarized, so they need to be installed in the correct orientation.

Note the stripe around one end: this marks the negative (minus) lead of the diode. On the circuit board, the printed outline of the diodes also shows this stripe. Install each diode so that its stripe matches the direction shown on the circuit board.

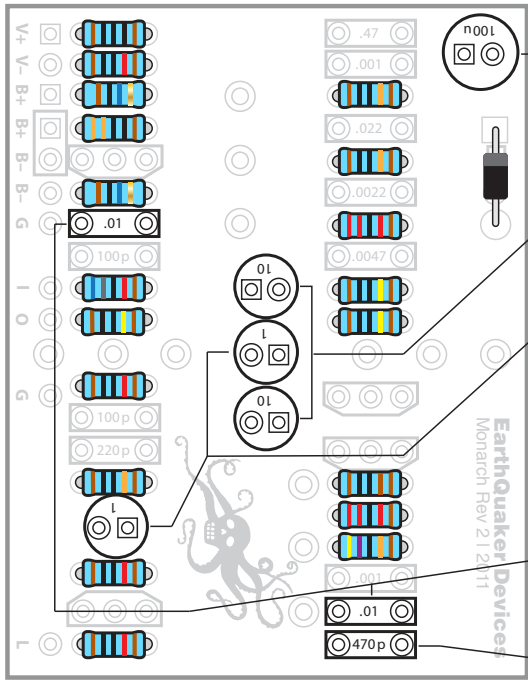

### Step 3: Install seventeen capacitors

The three types of capacitors shown below are polarized, and have to be installed in the correct orientation. Note the stripe running the length of each cap; this identifies the negative (minus) lead. On the circuit board, the circle for this cap's location has a round through hole on one side, and a square through hole on the other: insert the capacitors with their stripe facing the round hole side. (On polarized caps of this type, there's a second way to identify the minus lead: it is the shorter of the two leads.)



-  100µF capacitor (1) #7339
-  10µF capacitors (2) #7338
-  1µF capacitors (2) #7337

The remaining capacitors below are not polarized. Solder these caps in place facing either direction.

-  .01µF capacitors (2) #7331
-  470pF capacitor (1) #7328

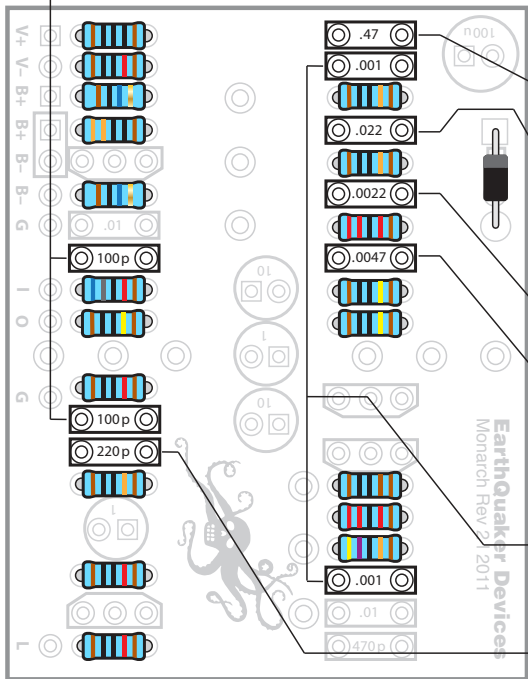

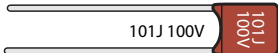
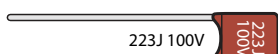
-  100pF capacitors (2) #7326
-  .47µF capacitor (1) #7336
-  .022µF capacitor (1) #7332
-  .0022µF capacitor (1) #7330
-  .0047µF capacitor (1) #7321
-  .001µF capacitors (2) #7329
-  220pF capacitor (1) #7327

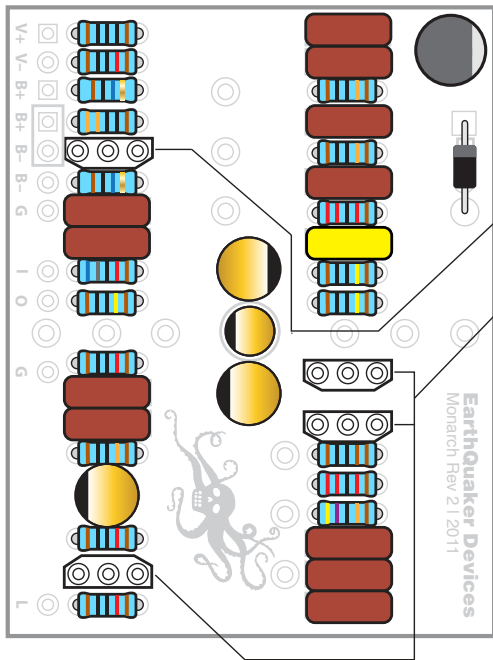

#### Step 4: Install four transistors

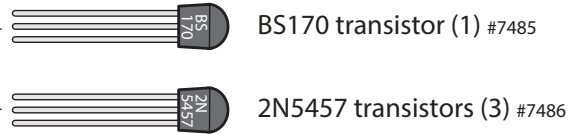

Transistors are directional, and they need to be installed in a specific direction to function properly. Note that each transistor has a flat side. On the circuit board, their locations have one side with a single flat line. Install the transistors to match their outline.

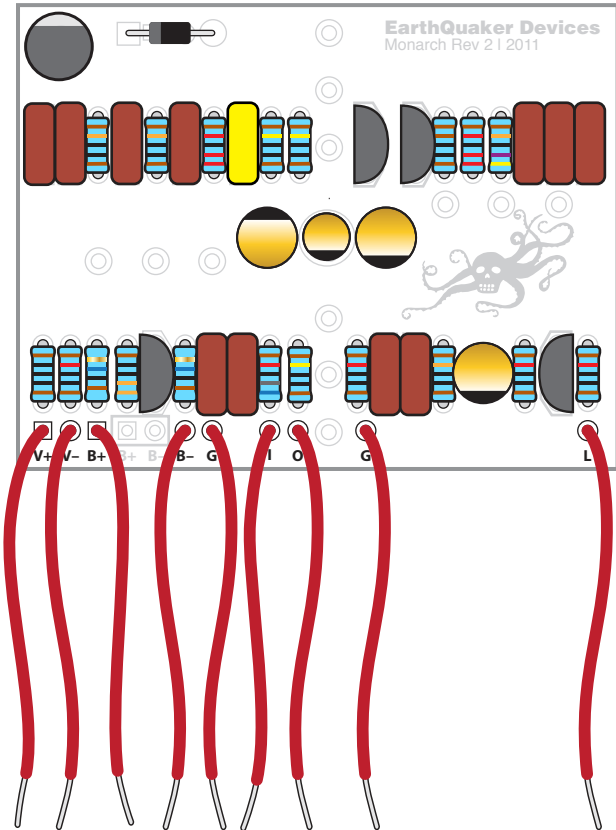

#### Step 5: Install nine lead wires



The kit comes with 24" of lead wire. Cut the wire into 2" sections. This will give you twelve 2" sections.

Strip around 3/32" of both ends of the 2" pieces. On one of the 2" pieces, strip 1/4" off one end and 3/32" off the other. This allows this wire to jump lugs on the footswitch.

Nine lead wires will be installed in eyelets; V+, V-, B+, B-, G, I, O, G, and L. Leave the second B+ and B- eyelets inside the rectangle open for the next step.

The two extra wires will be used to connect the jacks to the footswitch. Note: save the wire with 1/4" stripped for this step. There will be one extra wire not needed.

## Step 6: Install one 9V battery clip

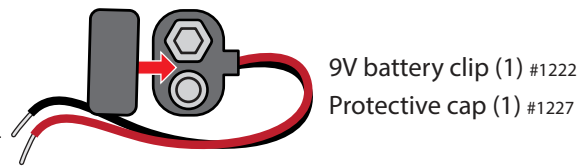
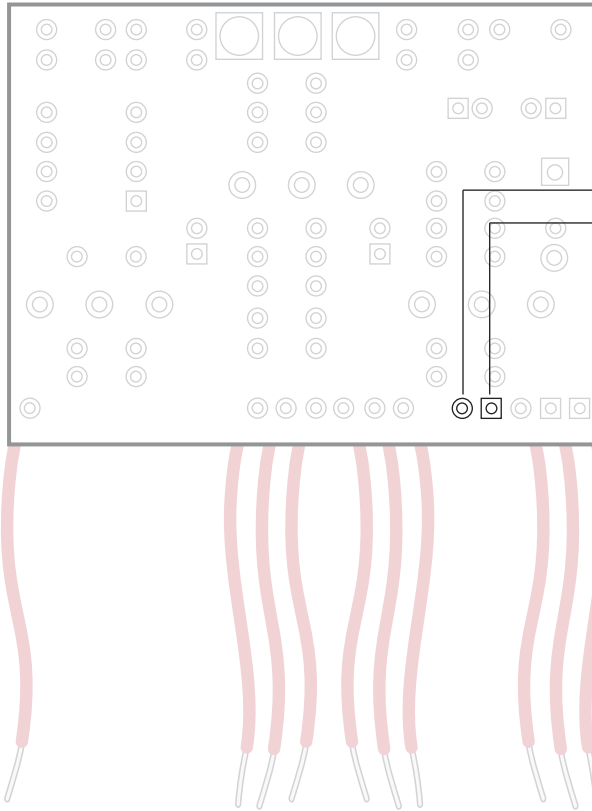

9V battery clip (1) #1222  
Protective cap (1) #1227

Place the 9V protective cap on the 9V clip. This cap protects the battery clip from coming in contact with the other electronic components.

Flip the board over, the 9V battery clip will be installed on the **back of the board**. The 9V battery clip has two leads, black (negative) and red (positive). The black lead goes to eyelet B- and the red lead goes to eyelet B+. The leads must be installed in the proper eyelets to function properly.



**Step 7: Install four control pots**

The last components to go onto the circuit board are the four control pots. They install on the **back of the board**. Each pot has three connecting lugs, refer to the below left graphic to be sure your orientation is correct when installing the pots.

If any pot has an index pin protruding from the case, break it off before installation, so the pot will mount flush against the pedal case. Needle nose pliers work well for removing the pins.

Use the **adhesive foam tape** to insulate the back of the pots from the soldered leads of the other parts on the circuit board. Solder the pot in place, making sure the foam back sits at the back of the board.

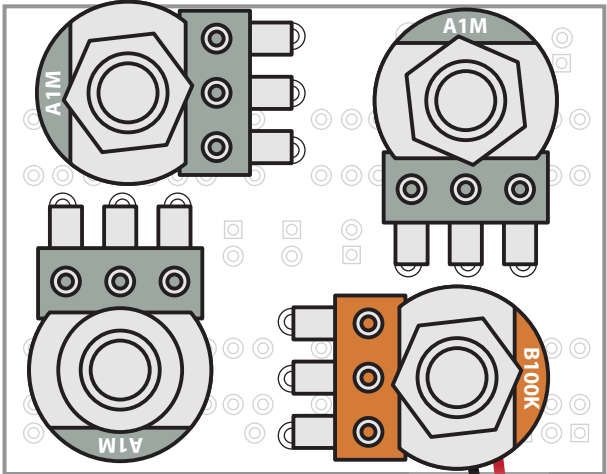
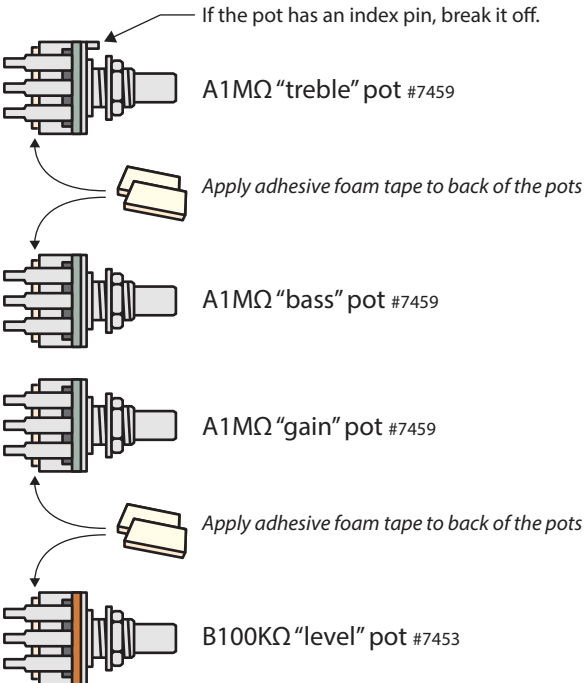
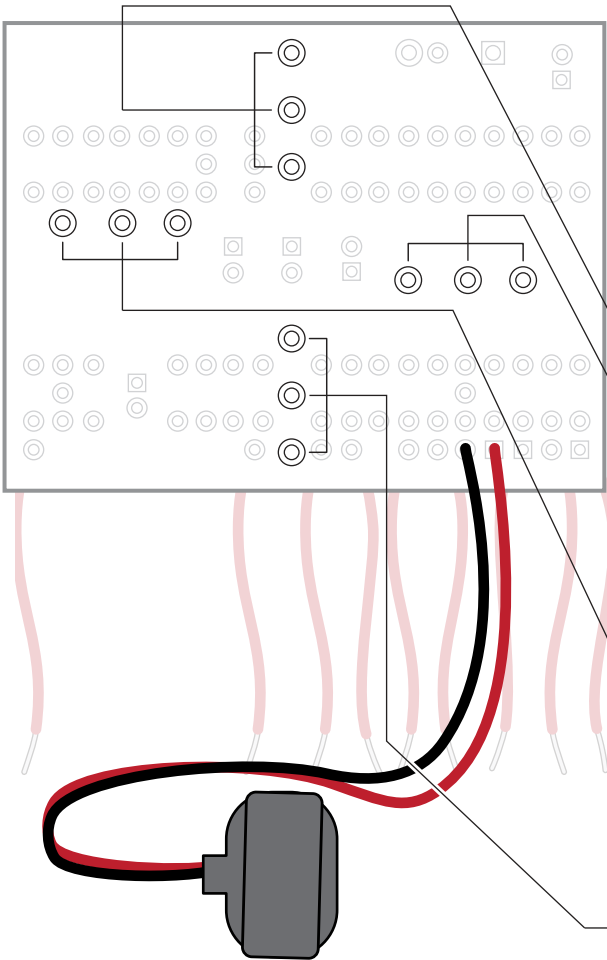

Refer to the left graphic to be sure your orientation is correct when installing the pots.

### Step 8: Install one LED indicator light

The LED mounting bezel consists of two main parts: A ring that the LED fits into, and a plastic plug that goes over the LED from the back side to keep it in place.

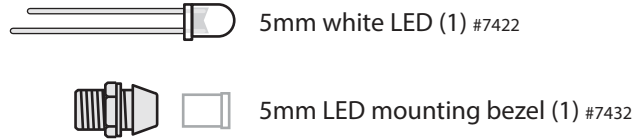

Like some of the caps and diodes, the LED is polarized and has to be installed in a specific direction. One side of the diode has a flat edge, indicating the negative lead. Another indication is that the negative lead is shorter than the positive.

Install the mounting bezel through the front of the enclosure. From the inside, slip a lock washer and nut on and tighten it up using a **3/8" socket**. Insert the LED into the bezel so the flat side (short lead) faces the hole for the footswitch. Feed the leads through the plastic plug, press the plug down until it's tight in the bezel. The LED will be held in place when you solder the leads to the switches and circuit board. For a more secure mount, you can run a bead of clear silicone adhesive around the plastic plug.

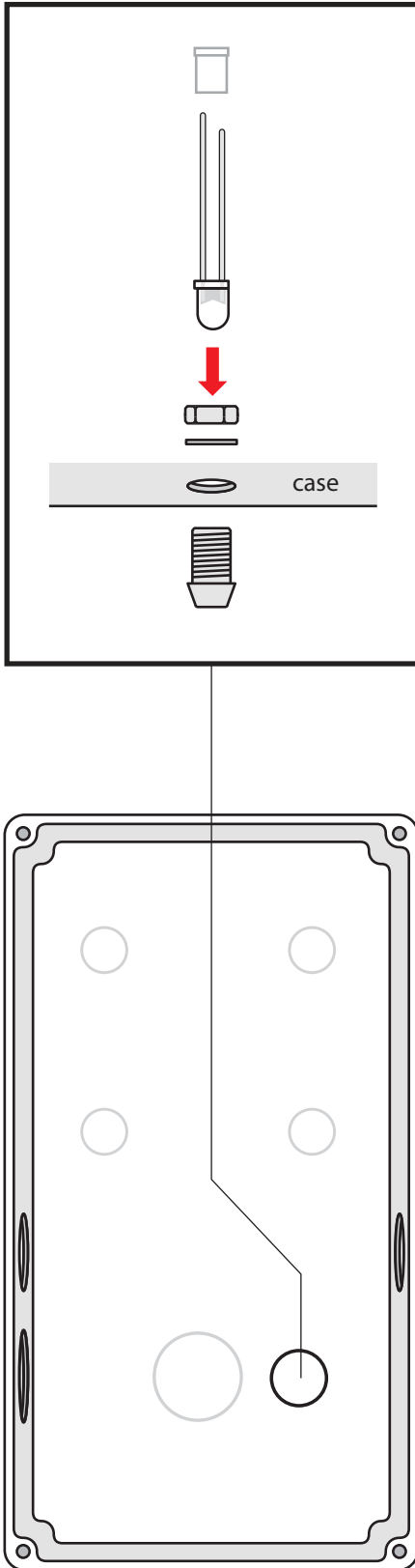

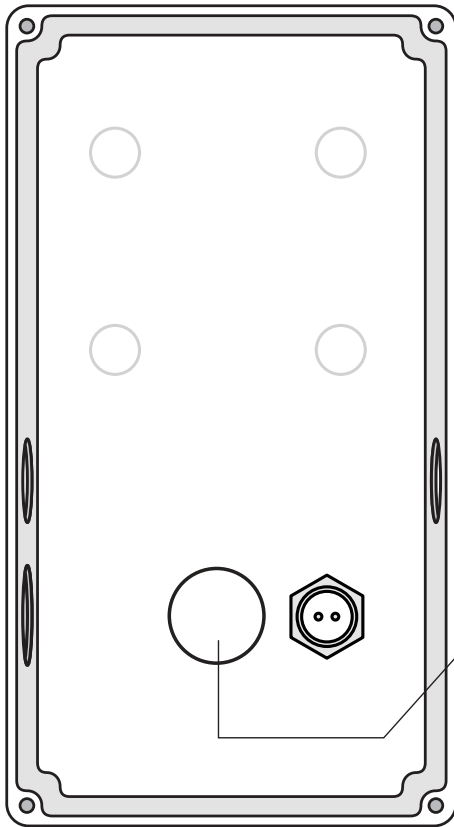

### Step 9: Install one footswitch

Install the footswitch so the part number printed on the side faces the bottom of the enclosure. Use a **14mm wrench** to tighten it up. The switch is the effect bypass switch that turns on the pedal.

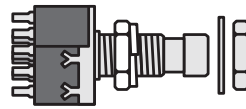

3PDT latching footswitch (1) #1611

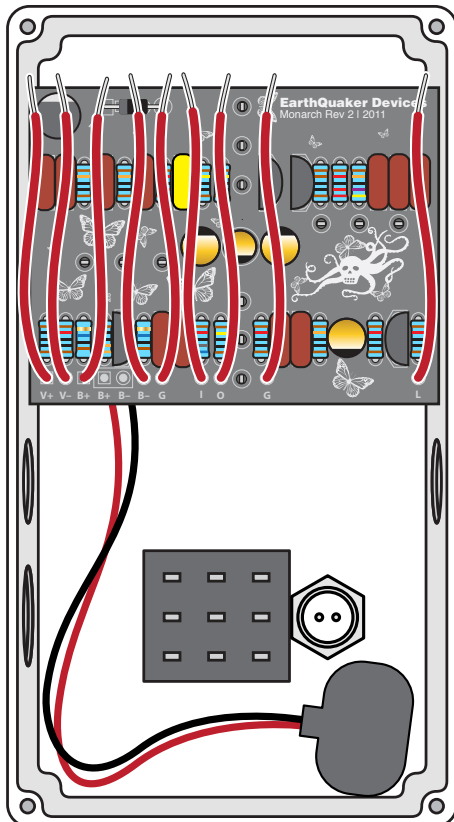

### Step 10: Install the circuit board

The circuit board is held in place by the control pots.

Install their shafts through the top of the case, and thread washers onto them on the outside. Using a **10mm wrench** install the mounting nuts so they are good and snug, but take care not to overtighten.

Do not connect any of the lead wires at this point.

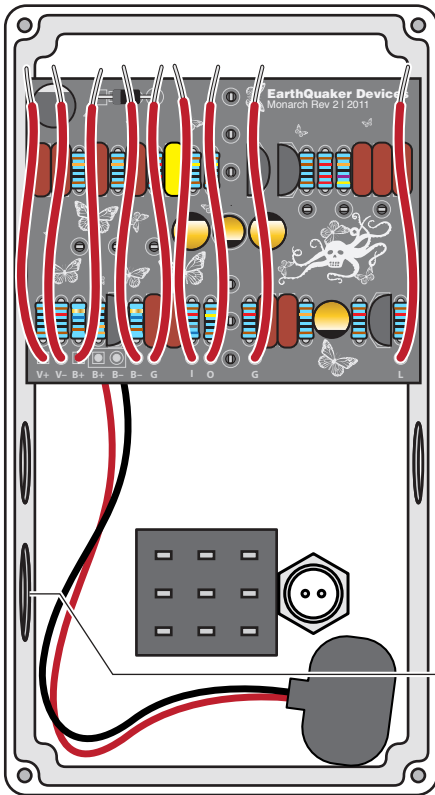

### Step 11: Install one DC jack

Install the DC jack using a **14mm wrench**.



2.1mm DC power connector (1) #7467

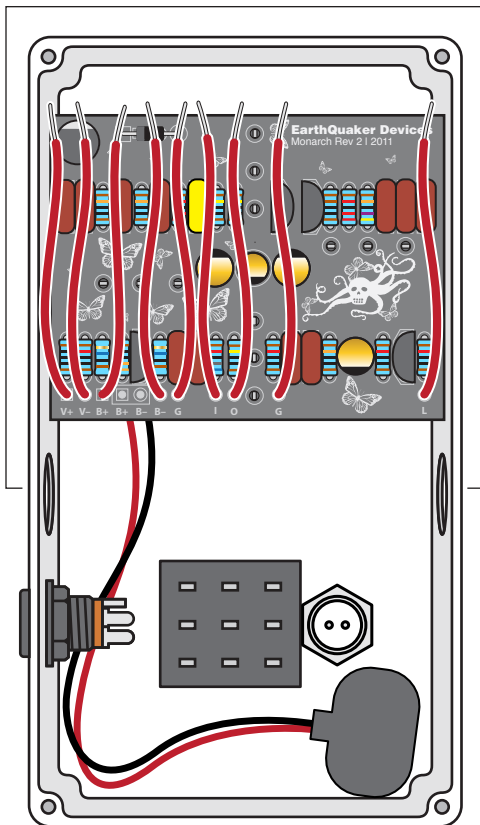

### Step 12: Install two jacks



#4653 Stereo jack (1)



#4652 Mono jack (1)

There are two different jacks for this kit, one stereo and one mono. The stereo jack is the input and the mono is the output. When looking at the back of the enclosure, the stereo jack will go on the left side and the mono on the right. Install the input and output jacks with the solder lugs facing up. This will make soldering easier later.

Run the 9V battery clip under the jack to keep it out of the way.

A **1/2" wrench** is recommended to tighten the jacks in place.

### Step 13: Final wire-up

With all of the components in place, it is time to wire it all up. Starting on the left-hand side of the circuit board, wire up the DC jack first. The wire labeled V+ connects to the +9V lug. V- connects to Masse (GND) lug. B+ connects to Battery + lug.

Next solder the input jack. Solder the wire labeled B- to the lug that connects to the shorter tip of input jack. This will disconnect the battery when unplugged. Next solder the wire labeled G to the sleeve lug on the input jack. This lug connects to the threaded shaft of the jack.

Continuing, solder the wire labeled I to lug #1 on the footswitch. Solder the wire labeled O to lug #4. Finally, solder the wire labeled G to lug #7.

Solder the final wire labeled L to the positive (long) lead of the LED.

Moving on to the footswitch, solder a wire to lug #2 then solder the same wire to the lug of the input jack that connects to the longer tip. Solder the wire with the 1/4" striped end to jumper lugs #3 and #5 on the footswitch, then solder the same wire to the tip lug of the output jack. Finally solder the negative (shorter) lead of the LED to the #8 lug of the footswitch.

Add a battery, if you would like. Screw on the back panel and plug in!

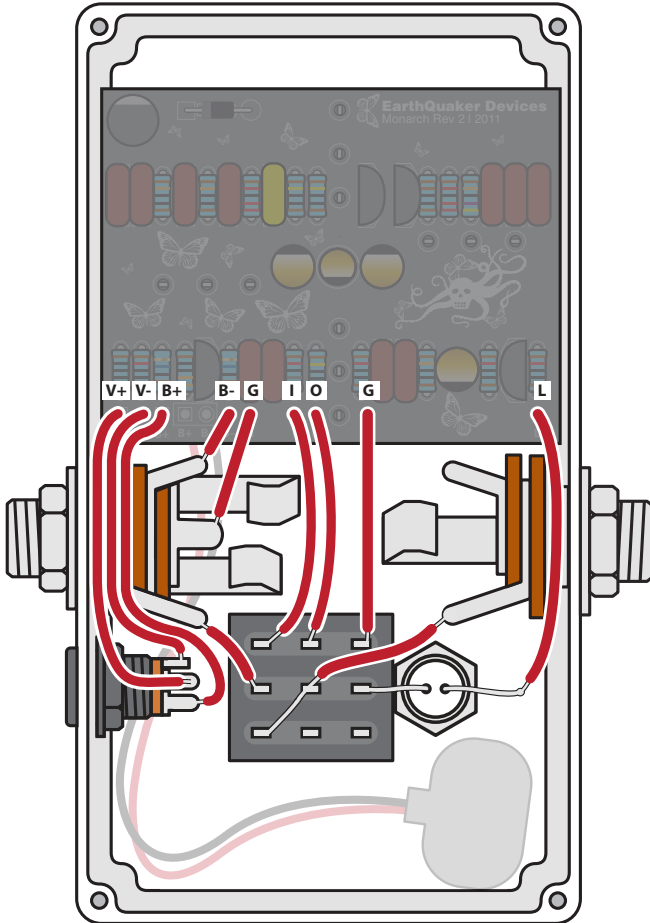

The lugs on the DC jack are as show above.

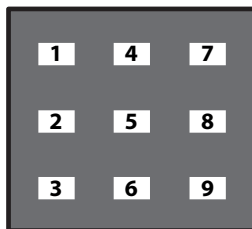

The lugs on the footswitches are numbered as shown above.

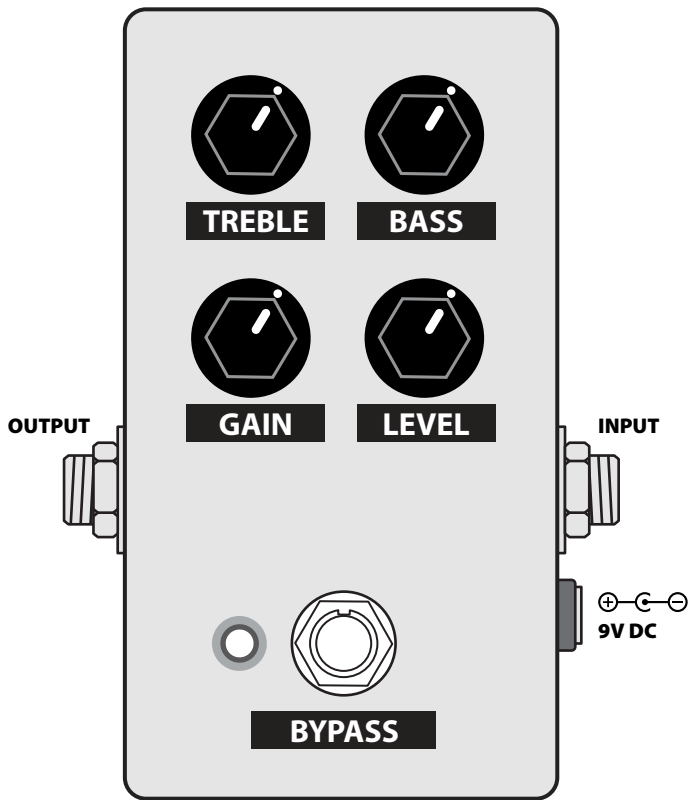

### Here's how the controls work:

---

**Treble:** Boosts the highs.

**Bass:** Boosts the lows.

**Gain:** Adjusts the amount of drive.

**Level:** Adjusts the output level, unity is around 9 o'clock... This thing is LOUD!

**Power:** Use a standard 9 volt DC power supply with a 2.1mm negative-center barrel (not included). We always recommend pedal-specific, transformer-isolated wall-wart power supplies or supplies with separate isolated outputs. Pedals will make extra noise if there is ripple or unclean power. Switching-type power supplies, daisy chains and non-pedal specific power supplies do not filter dirty power as well and let through unwanted noise. **Do not run at higher voltages!** Current draw is 3 mA.