

StewMac®

G-STYLE GUITAR KIT

Assembly Instructions

Welcome to guitar building! If you're a first-time builder, this kit is a great way to start. You'll have fun and learn a lot.

This simple kit is an excellent entry into electric guitar assembly. It can be built with basic tools. You'll learn to cut the peghead shape, attach the neck, and wire it up. After you build it, we'll show you how to set it up to play tip-top.

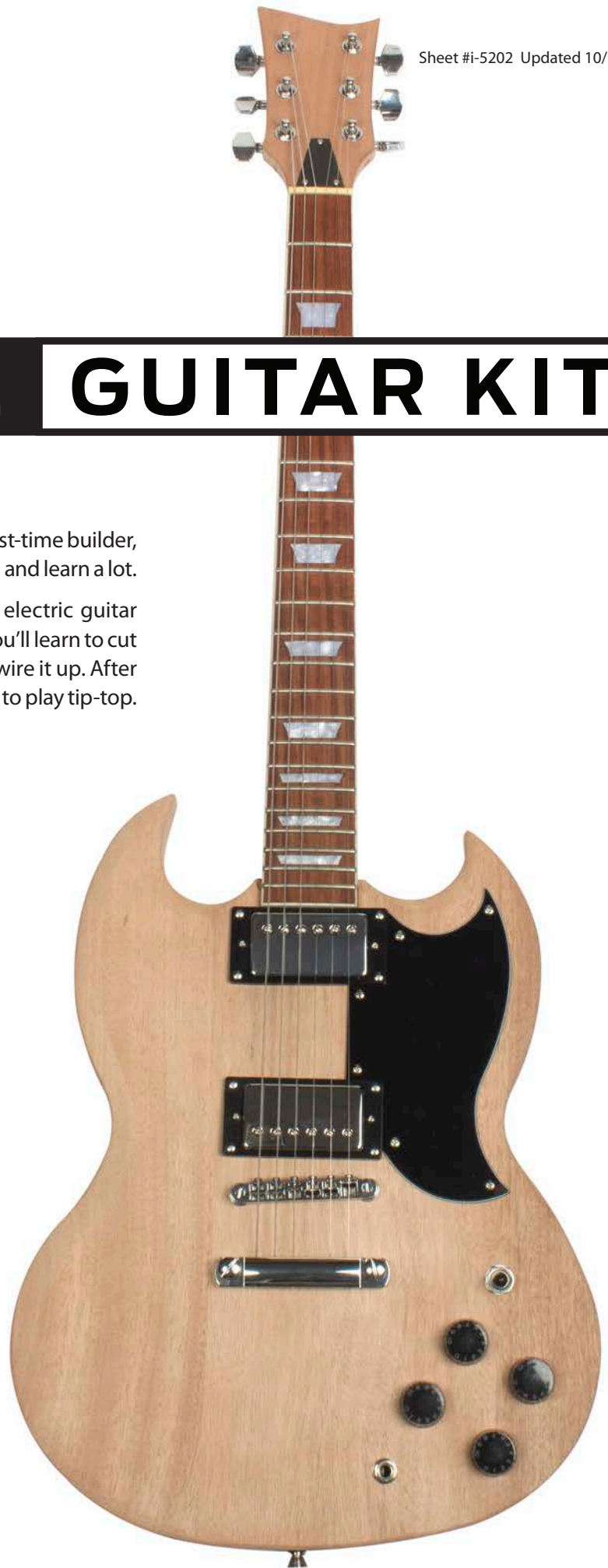

Table of contents

Tools and supplies	2
Parts list	3
Create your peghead shape	4
Set the neck	5
Fretwork	7
Assemble your guitar	9
Wire the electronics	11
Final setup	12

Tools and supplies

These are the tools and supplies we recommend for assembling this kit. StewMac item numbers are included where applicable.

Tools

Electric hand drill
Saw for peghead: band saw, jigsaw, or coping saw
Screwdrivers: Phillips, sizes #1 and #2 (#3000)
 Flat blade, size 5.0mm (#3000)
Drill bits: 1/16" (#1710)
 5/64" (#1712)
Nut slotting files: .013" width (#0823)
 .020" width (#0828)
 .035" width (#0832)
Fretting hammer (#4895)
Fret crowning file (#1602 or #4491)
Radius sanding block 12" (#0412)
Swivel handle clamp, total of 3 (#3704)
Straightedge (#3850)
6" Steel rule (#4905)
Nut driver, size 10mm (#5890, or wrench #3691)
Wire stripper, for fine gauge wire (#1606)
Adjustable wrench, 4" size (#1680)
Soldering iron (#0502 or #0515)
No-Chip Countersink (#1695)

Supplies

Wood glue (Titebond original, #0620)
Glue brush (#4167)
3M Scotch-Brite pad (#7445, light duty), or 0000 steel wool
Blue permanent marker
ColorTone Lemon Oil (#3864)
Guitar Finishing Step-By-Step Book (#5095)

Parts list



- 1 Neck
- 2 Body
- 3 Pickguard with mounting screws
- 4 Tuners with bushings, washers, and screws (6)
- 5 4mm hex wrench for adjusting truss rod
- 6 Truss rod cover with mounting screws
- 7 Strap buttons with cushions and screws
- 8 Generic strings for preliminary set up
(also included higher quality strings for actual use)
- 9 Hookup wire 9.5" and 5.25" lengths
- 10 3-way toggle switch
- 11 Capacitors (2)
- 12 Output jack
- 13 Solder
- 14 Humbucking pickups (set of 2)
- 15 Control pots with mounting hardware (set of 4)
- 16 Control knobs (set of 4)
- 17 Control cavity cover with mounting screws
- 18 Bridge with posts and bushings
- 19 Tailpiece with posts and bushings
- 20 Output cord

Create your peghead shape

You can trace a favorite peghead or come up with a look all of your own. You'll be cutting your design from the blank peghead on the kit's neck.

Make a template

Sketch out your peghead design on a piece of cardboard or heavy paper and cut it to shape with scissors. Using a pencil, trace the shape onto the peghead. Use a light touch that doesn't dent or compress the wood which could make sanding out any unwanted lines difficult. Don't use ink, because it leaves permanent stains that can even bleed up through an opaque guitar finish.

Cut the shape

It's important that your saw stays square to the face of the peghead while you cut. If it tilts to an angle, you'll get a sloppy result that takes a lot of sanding to correct. Use a bandsaw if you have one; a jigsaw is also good. A hand-held coping saw can also be used, but it's tough to hand-saw smooth clean curves.

Never cut on the line

Always cut just outside the line, so you can sand to the line afterward.

Smooth your saw cuts to create your peghead shape using rasps, files and sandpaper. Don't rush: rough patches will disappear into a good final shape if you take your time.

When you're happy with your peghead shape, sand the cut edges smooth using 150-grit sandpaper followed by 220-grit, then 320-grit.

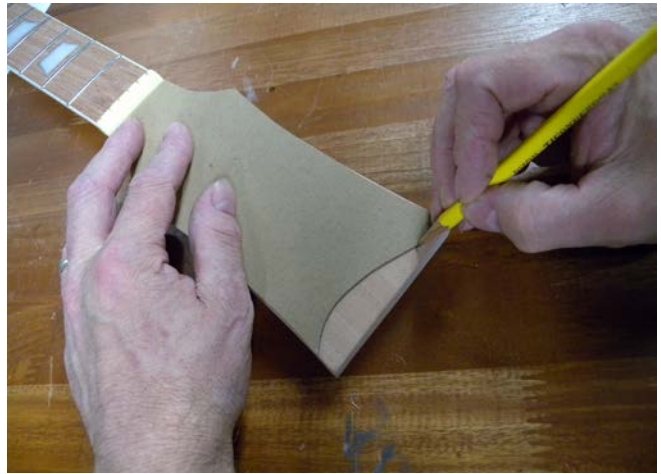

Set the neck

This is a set-neck kit with a mortise and tenon joint, meaning the heel of the neck (the tenon) is glued securely into the neck cavity (the mortise).



Before gluing up the neck do a dry run first. Using two clamps and a caul on the back of the body to prevent denting the wood lightly clamp the neck into place. Note there will be side to side movement of the neck.

There will be some gaps and chips around the joint; this is normal for a production guitar. These will get filled when you prep for finishing.



Take a 12" ruler or straightedge and line it up along the treble edge of the neck, paying attention to where it falls in relation to the treble side bridge stud hole. Then line it up with the bass side of the neck and check it to the bass side stud hole.



Set the neck

Loosen the clamps just slightly and adjust the position of the neck until you have even space between the bridge mounting holes. When achieved tighten the clamps securely. Mark a line in the cavity and on the tenon to use as reference when gluing up the neck.

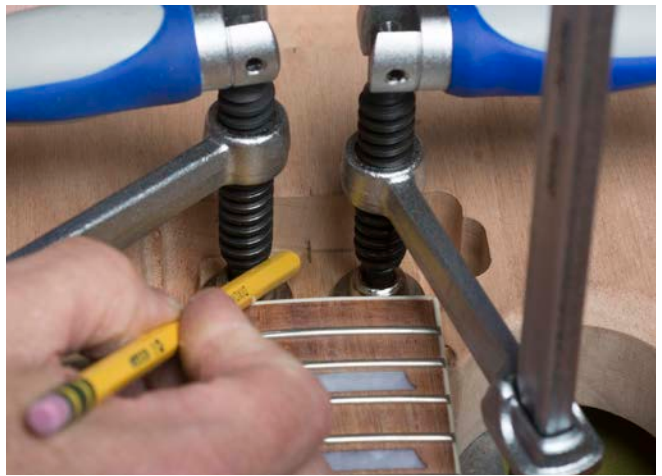

Make note of your actual gluing surface and spread glue on the bottom of the tenon. Repeat the same process as above using your reference line to get you in the ballpark. When properly aligned tighten up the two clamps on the tenon and add a third over the fretboard end using a radius caul to prevent damaging the frets.

Once the neck is seated remove any excess glue squeeze out with a damp cloth. Watch for further squeeze out over the next 15-30 minutes.

Let dry overnight.



Fretwork

Seat the frets

The frets come installed, but they need a little work to achieve the best playability. Use a fretting hammer to make sure the frets are all seated properly. The more even your fret tops are, the less leveling work there is to do later.



Run your fingers lightly along the edge of the fretboard and feel for sharp fret ends. If the fret ends feel sharp where they meet the edge of the neck, gently sand them back with 320-grit sandpaper using long strokes down the length of the neck. Use care not to change the bevel of the frets in the process.

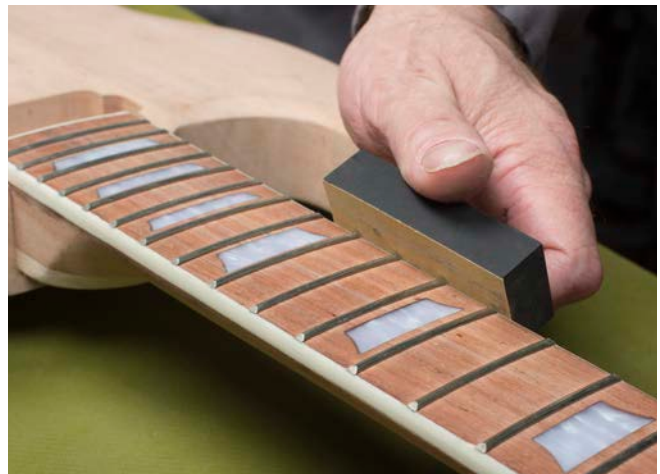

Straighten the neck

Use the 4mm hex wrench to adjust the truss rod. With a straightedge on the frets, adjust the truss rod until the straightedge touches all of the fret tops without rocking.

Turn the truss rod nut counterclockwise (viewed from the peghead end) to loosen the truss rod, allowing the neck to bow upward. Turning it right tightens the rod, pulling the neck back.

For more information, see our Trade Secrets article #33 "Don't be nervous about adjusting that truss rod!" at stewmac.com.



stewmac.com search: 

Fretwork

Color the fret tops with a blue permanent marker to prepare them for leveling. The blue ink will show your progress: the frets are level when sanding has removed some of the blue across all of the fret tops.



Level the frets

Use adhesive backed sandpaper or double-stick tape to attach 320-grit sandpaper to the 9.5" radius sanding block. With this, level the frets using full length strokes down the fretboard.



Leveling will leave flat tops on the frets. Use a fret crowning file to restore their rounded shape.

Reapply blue marker to the fret tops. By filing the sides of the frets, bring in the edges of the flats left over from leveling. With a rounding motion, keep bringing in these edges until all that remains of the top is a very thin line. Don't remove this line entirely; filing the fret tops would undo your leveling.



Polishing the frets

Using 400 grit, then 600 grit sandpaper wrapped around a foam block, run up and down the entire length of the fretboard. Polish the frets by going over each one with extra fine Scotch-Brite or 0000 steel wool. Follow up by cleaning the fretboard with ColorTone Lemon Oil or your favorite conditioner. Use care not to get any excess oil on the bare wood.



Assemble your guitar

Assemble your guitar on a soft pad or cardboard to prevent denting or scratching the instrument.

Install the tuners

Starting with the bottom set of pegholes, lay out the tuners with a ruler to make sure they are in line with one another. Mark out the mounting holes with a scribe or transfer punch.

Tuner mounting screws are very delicate. Use a 5/64" drill bit to make pilot holes for the screws; if these holes are any smaller you risk shearing off the screw heads. Lubricate the screw threads by dragging them across soap or wax for smooth installation.

With the tuners in place, install the screws in the pilot holes with a #1 Phillips screwdriver. On the tuner string post, add a washer then the threaded bushing. Tighten with a 10mm nut driver or wrench.

Install the body bushings

Install the tailpiece bushings. It's a good idea to slightly chamfer the holes for the bushings to prevent any chipping. Cut the edge back just larger than the outside diameter of the knurling.

Note that there is a ground wire access hole connecting the treble side tailpiece post hole to the control cavity, this is for the string ground. The 7" ground wire needs to be installed before the bushing. Strip 1/2" off of both ends and run the wire through the hole into the cavity leaving the stripped end to come in contact with the bushing once installed.



Install the tailpiece bushings. Pressing them in with a drill press is the preferred method but they can also be installed with gentle hammer taps using a block of wood between the bushing and hammer.

Install the bridge bushings in the same fashion.

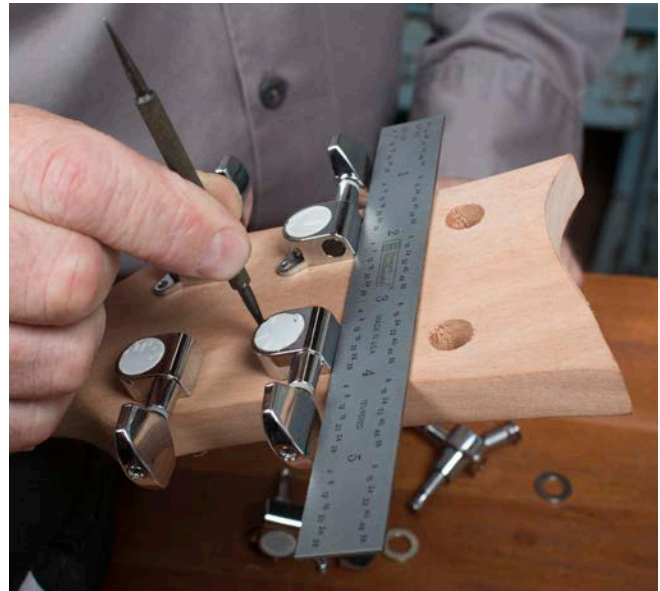

Bushing hole
before chamfering



Bushing hole
with chamfer



Ground wire
in bushing hole

Assemble your guitar

Drill for cover plates and pickguard

Use a sharp point, such as a scribe (#1672), to mark out the mounting holes for the control cavity cover and truss rod cover. Then, drill pilot holes for the screws using a 1/16" bit stopping at 3/8" deep. Next, center the truss rod cover over the truss rod cavity and mark it out. Using a 1/16" bit, drill holes 3/16" deep.



Install the strap buttons

Mount the tail strap button. The top button screws into the back of the body, just beyond the heel. Drill a 3/32" pilot hole, 1/2" deep.



Install the pickups

Drop the bridge and neck pickups in place. The pickup with the taller mounting ring is the bridge pickup, the pickup with the short mounting ring is the neck pickup.

Install the tune-o-matic bridge and tailpiece. String up the low and high E strings from the generic string set, to use as reference.

Line up the neck pickup so it is square to the end of the fretboard and the E strings are evenly above the polepieces. Mark the locations of the holes.

Now carefully line up the bridge pickup to make sure it is square to the neck pickup, temporarily positioning the pickguard in place will help with this step. After you've marked the holes, remove the strings and pickups. Then drill the holes with a 1/16" bit, 3/8" deep. Install the pickups. After the pickups are mounted attach the pickguard with the same bit and depth mentioned above.



Wire the electronics

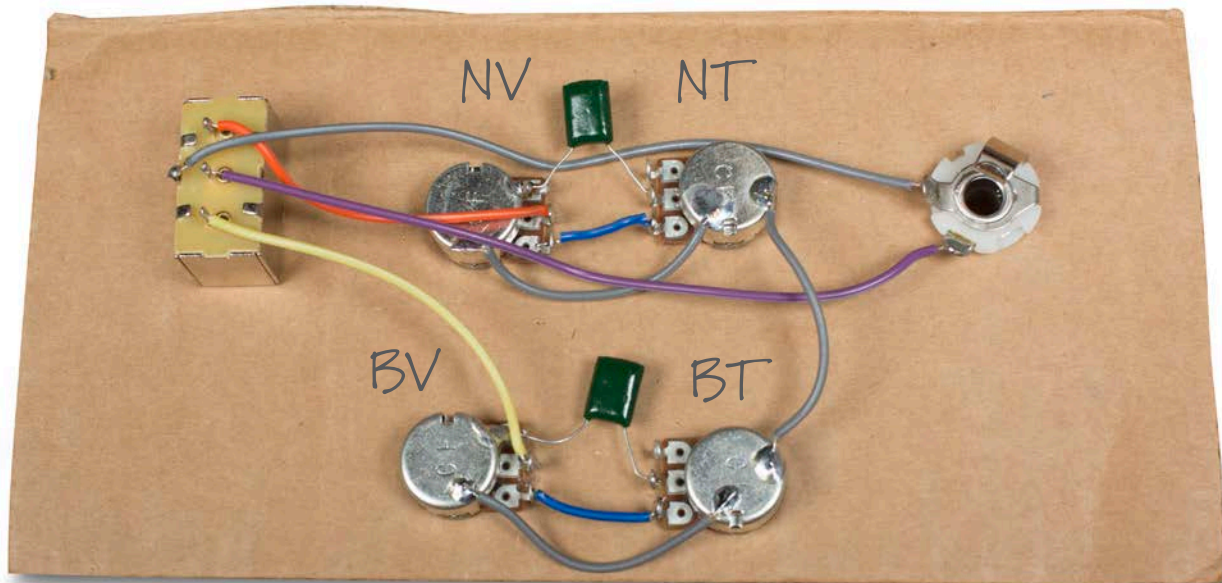

This kit comes with 9.5" and 5.25" lengths of hookup wire, more than enough wire than you'll need but it gives you plenty of extra in case something accidentally gets cut too short. The longer lengths are for running the string ground and output jack, the shorter for connecting the pots and switch.

Make a cardboard template that matches the hole pattern of the controls for proper parts spacing and easy soldering. There are two different taper control pots included, 2 A500k pots for volume and 2 B500K pots for the tone controls. Peel the wires apart and cut to length giving yourself a little slack between components. Strip about 1/8" of the insulation off of the ends of each wire, twist each end tight then coat them with a little solder; this is called "tinning". Tinning the wire ends as well as the lugs on the switch, pot, and jack will help your solder joints flow together quicker and cleaner.

Solder up your circuit following the wiring diagram to the right.

For help with soldering, see our Trade Secrets video #186 "How to get a good clean solder joint!" at stewmac.com.

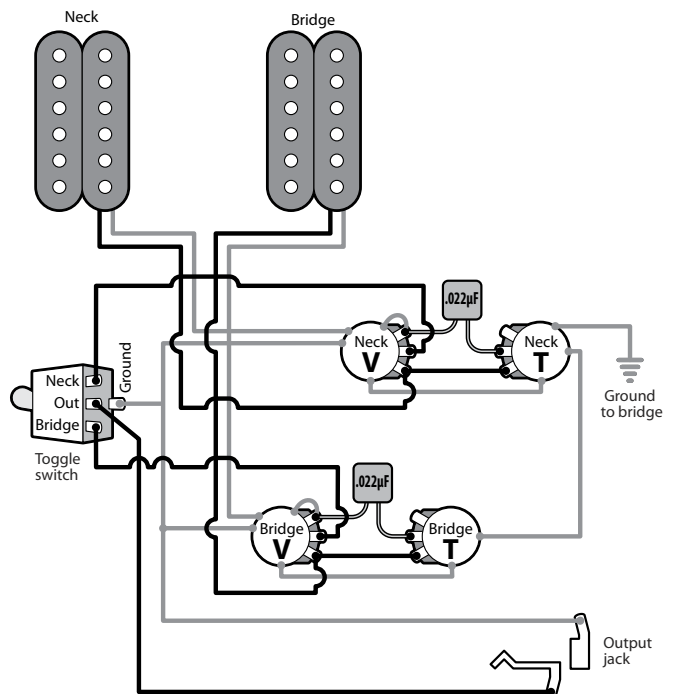

stewmac.com search:

Final setup



Adjust the neck

Install the remaining generic strings.

Neck relief refers to adjusting a neck so that it has a very slight upbow, rather than being perfectly straight. This relief allows a little more room for string vibration, reducing the chance of hitting the lower frets and causing fret buzz.

Depending on your playing style, and how perfectly level your fret tops are, a neck should be anywhere from perfectly straight to having 0.012" of relief. This measurement refers to additional string height over the 12th fret, compared to a perfectly straight neck.

A straight neck tends to play and sound better, but very few guitars end up with no relief at all, and several thousandths of an inch or more is perfectly normal.

You can use a straightedge or the low E string to get you in the ballpark. Using your index finger, hold down the E string at the first fret. With the other hand, hold down the string at the 17th fret with your thumb and use your index finger to check for relief. The smaller the gap between the bottom of the string and the top of the frets, the straighter the neck.

Turn the truss rod nut counterclockwise to bring the neck up, adding relief.



Measure string relief at the 12th fret.



Turn clockwise to pull the neck back, reducing relief. Go slow: a little does a lot!



Lower the nut slots

Once the neck is adjusted to the desired straightness, the nut slots will need to be lowered for the best playability. Measure the gap between the bottom of the string and the top of the 1st fret.

A comfortable medium action over the first fret is .012" for the plain strings (G,B,E), and .020" for the wound strings (E,A,D).

Use feeler gauges to measure the gap or use guitar string scraps whose gauges match the measurement you are shooting for. Using just a few file strokes at a time, stop filing when the string sits on the top of your feeler gauge, whatever it may be. Take your time and check your work frequently. It is easy to go too far lowering the slots thus ruining the nut.

Set the string height

Adjust the bridge action using the thumbwheels on bass and treble sides. Measure the gaps between the bottom of the low and high E strings and the top of the 12th fret.

Factory action for the high at the 12th fret is $1/16''$ for the high E string, and $5/64''$ for the low E.



Adjust the pickup height

One at a time, hold the low and high E strings down at the 22nd fret.

Adjust the neck pickup to $1/16''$ between the bottoms of the low and high E strings and the top of the pole pieces. Adjust the bridge pickup to $3/32''$.



Set the intonation

The last step is intonating the guitar by adjusting the string lengths at the bridge saddles. This will help ensure that the guitar plays in tune all the way up the neck.

Remove the generic strings and install the higher quality set.

Tune the strings to pitch using a strobe or other accurate tuner. Then, press the high E string lightly at the 12th fret with just enough pressure on the fret to sound the note. Check it with your tuner.

If the note reads flat, the saddle needs to be adjusted forward towards the nut, shortening the length of the string. If the note reads sharp, the saddle needs to be adjusted back away from the nut, increasing the string length.



You're done!

Congratulations!

Your guitar is now ready for finishing. We hope this guitar will be the first of many that you have fun assembling and customizing. For detailed information about applying a great looking finish check out our book *Guitar Finishing Step-By-Step*.

Be sure to get a gig bag or case, so it doesn't get banged around!





21 N. Shafer St • Athens, Ohio 45701 • USA
USA & Canada call toll-free: 800-848-2273
9am-6pm weekdays Eastern time

stewmac.com