



VALVE FACTORY 1

1W AMPLIFIER KIT
INSTRUCTIONS

The first amp you can build in a weekend.

stewmac
making guitars better

Contents

- Introducing the VF1 3
- Get to know your parts list 4
- Tools and supplies 6
- Important: Build cautiously and safely** 7
- Understanding capacitors and resistors 8
- New to amp building? Tips and tricks 9
- Build order and understanding illustrations 10
- Pre-populated circuit board final prep 11
- Install plates, prep/install power jack, bridge rectifier and 2200µF cap 12
- Install ON/OFF switch, speaker jack, output transformer 14
- Install remaining rectifier wire, prep one terminal strip 15
- Install V1/V2 components, input jack subassembly 16
- Solder input jack wire, install input jack, connect V1/V2 heaters 17
- Install PCB, output transformer primary leads and V1/V2 components 18
- Prep/install V1/V2 wires and V1 resistor assembly 19
- Install/solder remaining V1/V2 parts, install pots/pot components 20
- Install film capacitor, attach power transformer 21
- Testing, add feet, closing 22
- Attach control knobs to pots, explain tube plate 23
- Completed drawing and photograph 24
- Insight on tubes 26
- Geek Alert! VF1 schematic 28

COPYRIGHT WARNING

This material is protected by copyright and has been created by and solely for the purposes of StewMac. You may not sell, alter or further reproduce any part of this material, or distribute it to any other person. Where provided to you in electronic format, you may only print from it for your own private use. Failure to comply with the terms of this warning exposes you to legal action for copyright infringement.



VALVE FACTORY 1
1W AMPLIFIER KIT

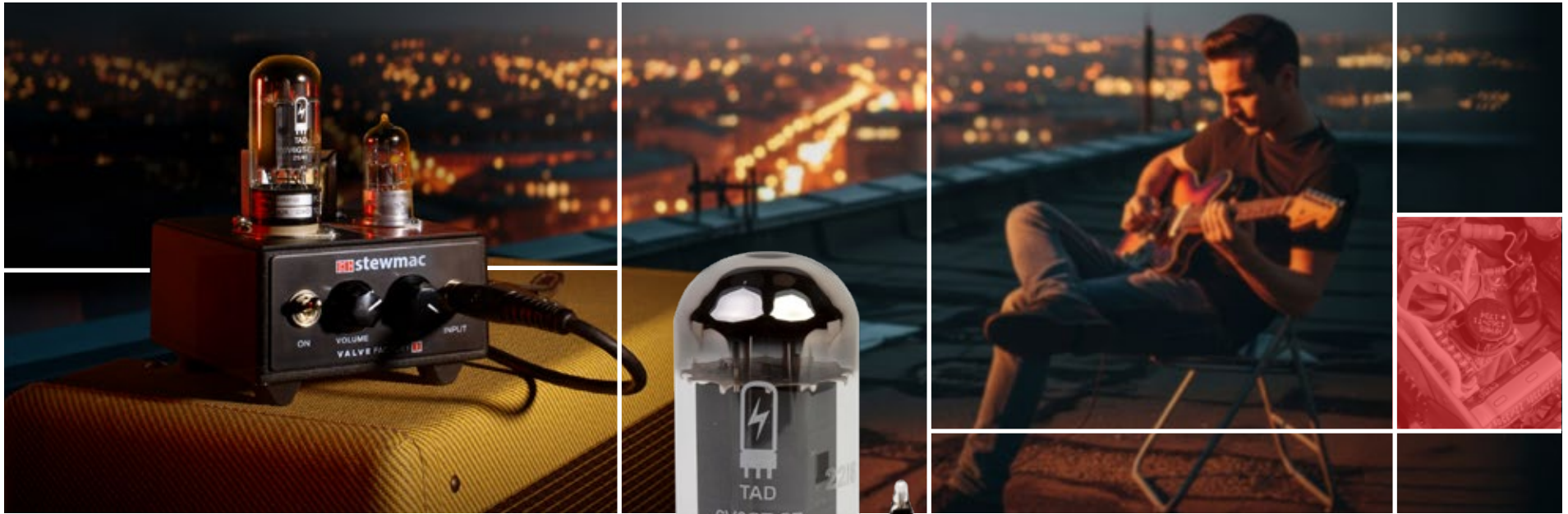

The amp you and your neighbors will be glad you built

It's probably safe to say that most guitar players love the tone that a tube amp produces and have fantasized about one day building their own. However, to the novice amp builder, building an amp can seem complex, costly and potentially dangerous. These are just a few reasons we developed the StewMac Valve Factory 1. This affordable little amp is the perfect at home weekend project that's relatively simple to build, and unlike other amps that store high voltages, the Valve Factory 1 only uses a 9V pedal supply so it's ideal for someone just entering the amp building on-ramp.

The Valve Factory 1 produces that warm, rich harmonic, naturally distorted, slightly overdriven sound that you'd expect from a tube amp, but does so at volume levels that won't have your neighbors calling the cops.

While this low volume benefit may not make this 1 watt amp ideal for your next gig, its light weight body, compact size and easy to remove tubes make the Valve Factory 1 the ideal tube amp to stash in your suitcase while traveling.



Through this build you'll not only learn what makes an amp tick, you'll discover how rewarding and empowering building an amp can be. The Valve Factory 1 looks great, sounds great, and is a great first step on your amp building and tone chasing journey.

Build it with StewMac

These immersive instructions walk you through every step of creating your StewMac Valve Factory 1. Follow our steps closely for safety, too: we've carefully laid out a path that even newcomers can follow in handling electrical components. Building an amp can seem daunting, but nobody makes it easier than StewMac. Watch for helpful tips along the way, too—we're here to help!



When you see this icon through this instruction manual, take a little time to read through the helpful tips and tricks.

Parts

i Know your parts. Taking a minute to become familiar with and organize your parts well before you jump into building your amp will save you a ton of time in the long run.



Identifying numbers, letters, and color bands on parts isn't always easy. To make the process more efficient, we've sorted the smaller parts into a couple of tackle boxes. However, we recommend always having both a magnifying device and a multimeter on hand.

Resistors



Brown Gray Black Brown Brown

- (1) 1.8K 1/2W metal film



Brown Green Black Brown Brown

- (1) 1.5K 1/2W metal film



Brown Black Black Yellow Brown

- (1) 1M 1/2W metal film



Brown Black Black Orange Brown

- (2) 100K 1/2W metal film



Red Red Black Orange Brown

- (1) 220K 1/2W metal film



Orange White Black Red Brown

- (1) 39K 1/2W metal film



Violet Green Brown Gold

- (1) 750Ω 3W metal film

Prepopulated Circuit Board

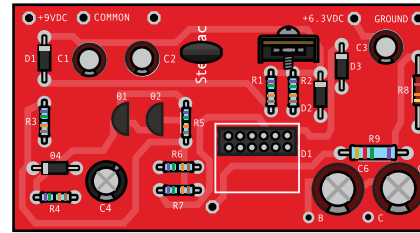

- (1) PCB prepopulated sub assembly

Capacitors

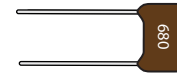

- (1) 680pF 500V silver mica

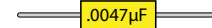

- (1) .0047µF 630V film capacitor

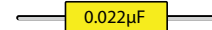

- (1) .022µF 630V film capacitor

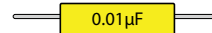

- (1) 0.01µF 630V film capacitor



- (1) 0.47µF electrolytic capacitor



- (1) 1µF electrolytic capacitor



- (1) 2200µF electrolytic capacitor

Tubes and sockets



- (1) Nine-pin tube socket

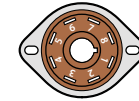

- (1) Eight-pin tube socket



- (1) 12AX7/ECC83 preamp tube



- (1) 6V6GTCZ power tube

Transformers and power

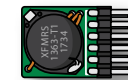

- (1) PCB power transformer

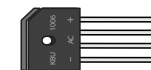



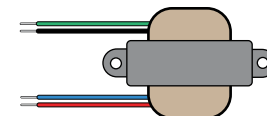







- (1) Bridge rectifier



- (1) Output transformer

Hardware

-  (1) 6-32 machine screw, 1/4"
-  (2) 6-32 machine screws, 3/8"
-  (2) 6-32 locknut with external tooth
-  (6) 4-40 machine screw, 3/8"
-  (6) 4-40 locknut with external tooth
-  (1) #6 Solder lug
-  (1) Carling switch flat washer
-  (2) 3/8" nylon insulated grommets
-  (2) Metal standoffs
-  (4) Rubber feet

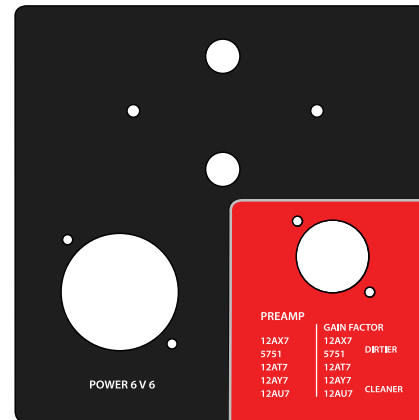
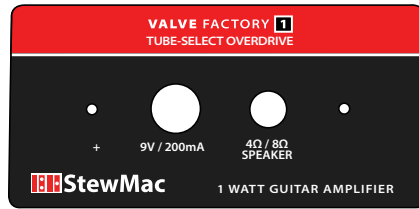



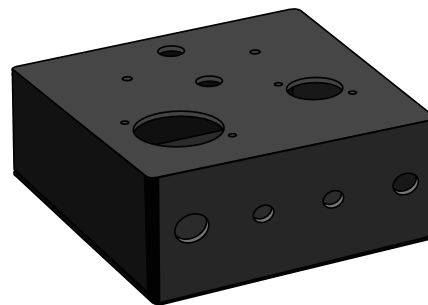

- (3) Front, back and top faceplates





- (1) Chassis (enclosure and cover plate)





Wire

-  20 AWG, 5", white pushback wire
-  20 AWG, 25", black pushback wire
-  20 AWG, 15", green pushback wire
-  20 AWG, 30", red pushback wire
-  20 AWG, 5", yellow pushback wire

Heat-shrink tubing

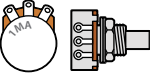
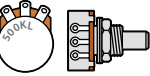
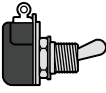
-  (1) 1/4" diameter (12" length)
-  (1) 1/16" diameter (6" length)

Control pots, input jacks and more

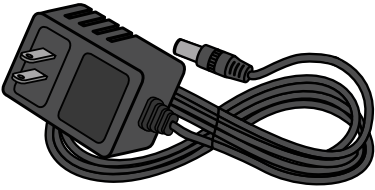
-  (2) Switchcraft jack, shunt tip
-  (1) 1M control pot (A-audio taper)
-  (1) 500K control pot (L-linear taper)
-  (1) Carling switch with metal nut
-  (2) MXR-style knob
-  (2) Three-lug terminal strip
-  (1) Power jack
-  (1) 9VAC power adapter

Tools and supplies

Required

Phillips screwdrivers, #1 and #2
Item #3000 Guitar Tech Screwdriver Set

Needle nose pliers
Item #1610 Long Nose Pliers

Round nose bending pliers
#1609

Wire cutter
Item #1607 Wire Cutter

Wire stripper
Item #1606 Wire Stripper

Soldering iron (preferably 40W)
Item #0501 Solomon SL-30 Soldering Station

Delta Solder 60/40
Item #103460 60/40
Item #103461 Lead Free

Solder Sucker
Item #0503 Solomon Solder Sucker

Rule
Item #4905 StewMac Shop Rule

Peakmeter PM19C
Item #3620

Alligator Clip Heat Sinks
Item # 0532-CU

Wooden chopsticks

Butane BBQ lighter
For heating heat-shrink tubing

Roll of multi-purpose tape
Item # 0678

14mm Wrench Set
Item # 3691



Helpful to have tools

StewMac PC Board Holder
Item # 0500

StewMac Guitar Parts Tray
Item # 10394

Adjustable Toggle Switch Wrench
Item # 1699

Soft Touch Pliers
Item # 1719

This amp doesn't pose to same level of potential danger as our other amp kits, these are still very helpful safety tips you should always adhere to. What better time to lay that foundation?

While we insist on the following safety precautions with most amp building or repair, the Valve Factory 1 does not pose the same level of potential danger. These safety tips should still be adhered to, however, use of a snuffer stick is not required and we simply urge caution while operating around capacitors once power is supplied to the build.

Wear rubber-soled shoes

Rubber soles increase the insulation between yourself and the ground.

Take off your ring

A metal ring on your finger can bridge a hot connection to ground.

Wear safety glasses

Rosin-core solder sometimes bubbles up, and it can spew molten specks into the air. You don't want molten solder in your eyes.

It's better not to work alone

Electrical shocks can incapacitate you, and having someone available to call 911 can be a lifesaver.

Take breaks and stop when you're tired

Fatigue leads to mistakes, and no one can afford mistakes when working with electricity.



Stay suspicious

Whether it's the first time you've been inside a live amplifier or the 100th time, don't become complacent. If you discharge the caps and walk away for a few minutes, check again for residual voltage when you return. Capacitors can self-charge through a phenomenon known as dielectric memory.

Check before powering on

It's easy to forget that you left a stray tool or wire in the chassis. It's also easy to forget to re-attach the speaker wire, and that can fry an output transformer in seconds. Constant vigilance is your friend when working on amps.

Always unplug your amp

Unplug the amp whenever you don't need it plugged in. Some points are always hot when the amp's plugged in, even if the power switch is off. These points include the lugs on the fuse socket, power switch, and standby switch.



How to use a snuffer stick

The snuffer stick is a specialty tool that is used to safely discharge dangerous voltage from capacitors before working on the amp.

To discharge a capacitor, clip the snuffer stick lead to ground—preferably a mounting bolt on the power transformer. Hold the tip of the stick to the cap's positive lead and use your multimeter to watch the voltage drain to less than 18V.



How to read resistor values

A resistor's value—the amount of resistance it creates—is rated in ohms (Ω). Larger ohm values mean more resistance. For example, a 100Ω resistor creates ten times as much resistance as a 10Ω resistor.

The resistors used in amplifiers are too small to have value numbers printed on them. Instead, a system of colored bands tells their values. The key to reading these bands is located to the right.

	Band 1	Band 2	Band 3	Multiplier	Tolerance
BLACK	0	0	0	1	
BROWN	1	1	1	10	+/- 1%
RED	2	2	2	100	+/- 2%
ORANGE	3	3	3	1,000	
YELLOW	4	4	4	10,000	
GREEN	5	5	5	100,000	+/- 0.5%
BLUE	6	6	6	1,000,000	+/- 0.25%
VIOLET	7	7	7	10,000,000	+/- 0.10%
GRAY	8	8	8	100,000,000	+/- 0.05%
WHITE	9	9	9	1,000,000,000	
GOLD				0.1	+/- 5%
SILVER				0.01	+/- 10%

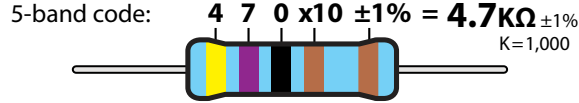

4-band code: read Bands 1 and 2 same as above, then Band 3 is the Multiplier and Band 4 is the Tolerance.

The first color in the code is usually the one painted closest to a lead. When a gold or silver band is present, it's always one of the last colors in the code. This indicates the tolerance allowed during manufacturing

Can't read the colors?

You can always use a multimeter to test a resistor's value. Set your meter to ohms and connect the test leads on each side of the resistor. Additionally, there are great apps and websites like DigiKey.com out there to help you identify parts accurately. Beyond color identification, it's a great practice to test every resistor with your multimeter, just to be certain the resistor is not faulty.



Capacitor values

Capacitor values are typically printed on the component. The key values with caps are their capacitance and voltage.

Think of a capacitor as a container that can hold electricity. Capacitance, measured in farads, refers to how much electricity this container can hold—its capacity. One farad (1F) would be much too large for use in an amplifier. Caps for amps are rated in millionths of a farad, called microfarads (μF), or trillionths of a farad: picofarads (pF). The voltage spec for a cap refers to how much DC voltage it can handle at any given time.

A unique property of capacitors is that they don't allow DC current to flow past them, only AC current. This is important in parts of an amplifier circuit, such as the path between a preamp stage and a power amp stage. Here, a "coupling capacitor" will block DC voltage, allowing only the AC guitar signal to pass.

Filter caps

Capacitors also filter out 60Hz hum, or "ripple," after the AC current from the wall is converted to DC. These capacitors are called filter caps, because they filter out the ripple from a power supply. The $22\mu\text{F}$ 350V electrolytic filter capacitors for this amp are already soldered to the power supply PCB.

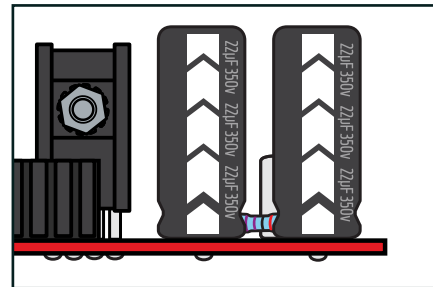

Though the voltages this amp handles are not quite as dangerous as your typical tube amplifier, it is still very important that you treat those specific solder joints with care and do not touch the power jack or PCB while that amp is plugged in.

Electrolytic caps

Electrolytic capacitors contain electrolyte: a liquid or gel that gives them a large storage capacity. Electrolytic caps are typically polarized.

Polarized caps

Some capacitors have polarity and some don't. It's extremely important to install polarized caps correctly in a circuit. The positive lead of an electrolytic cap will be indicated by an indented ring around one edge of the capacitor. The negative lead will often be indicated by a band of arrows pointing to the negative lead.



Installing capacitors with the polarity backwards will make the circuit malfunction and quickly destroy the capacitor—even causing it to explode.

New to amp building? Start here!

Electricity 101

The classic comparison for the flow of electricity is the flow of water. In which case, (V) voltage is the pressure at which the water is being pushed through a pipe, (A) amperage is the rate at which the water flows, and (Ω) resistance is a constriction in the pipe. To take that one step further, potentiometers would be a valve that you can open and close to change the flow of water.

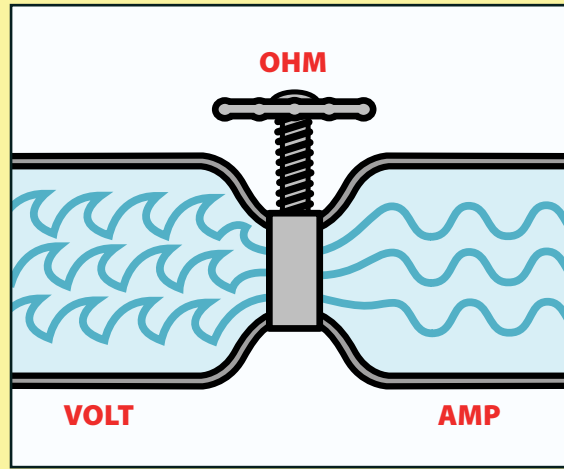

The Multimeter: Your New Best Friend

A multimeter is a device with two probes that you use to take various electrical measurements, and it is an absolute necessity if you want to work with electronics. Back in the day, there were separate voltmeters to read (V) volts, ohmmeters to read (Ω) ohms, and ammeters to read (A) amps. These days we have one meter that can perform all of those functions and more.

V Voltage (pressure with which electricity is moving) Almost all of your voltage readings in this kit will be read “from ground”, meaning one probe will be touching a ground point while the other is touching a live electrical connection in the circuit.

A Amperage (how much current is flowing at any point in the circuit): This is a function you probably won't need

to use with this kit, but amperage is important to understand if you want to have a strong grasp on electrical concepts.

Ω Resistance (opposition to the flow of electricity) You will be taking many resistance readings with this kit. The most prominent use is testing the value of resistors and potentiometers.

\rightarrow Continuity (yes/no test for low resistance path from one point to another) If you place your probes on two different points in the circuit and there is very low resistance between them, your multimeter will beep. If there is no connection or high resistance, your multimeter will not beep. It's a very simple but very handy test for making sure things are electrically connected.

To get good clean solder joints, follow these tips!

- ✓ **Wrap the leads tightly**
Good electrical contact starts with good mechanical contact before you add the solder. Don't use solder to “glue” loose joints.
- ✓ **Keep the iron clean**
Wipe the tip of the iron often on a damp sponge.
- ✓ **Keep the iron tinned**
Melt a small amount of solder onto the tip of the hot iron. This is called “tinning” the iron. Also tin component leads like multi-strand wires to help the solder flow.

- ✓ **Don't feed the solder to the iron** Hold the tinned tip against the joint for a few seconds until the connection reaches soldering temperature, then feed the solder to the joint. Keep the iron on the connection for a second longer to allow the flux to cook out of the joint.

Minimize hum by routing the heater wires carefully

AC voltage is 60Hz, which can be picked up as an unwanted hum, so it's very important to use these two techniques when you route these wires.

Twist the wires

Wire twisting isn't about keeping things tidy, it's about hum-cancelling. These intertwined wires reduce noise that can occur with straight wires.

✓ Don't blow on hot solder

Don't blow on the joint to cool it, or touch anything until the joint has completely cooled. A good solder joint is shiny—a sign that it was left to cool undisturbed.

✓ Trim excess leads

Cut away the ends of wires after the joint has cooled.

✓ Think twice, solder once

Plan ahead so each joint is only soldered once. Resoldered joints are messy and more likely to fail.

✓ Position the parts

Orient the parts so their specs face out so you can read them later. Many builders also align resistor bands to read in the same direction.

✓ Strip the insulation

How much insulation to strip? With plastic insulation, strip 3/8" from the wire ends. Push-back wire works best when you strip away about 1/4" of the cloth.

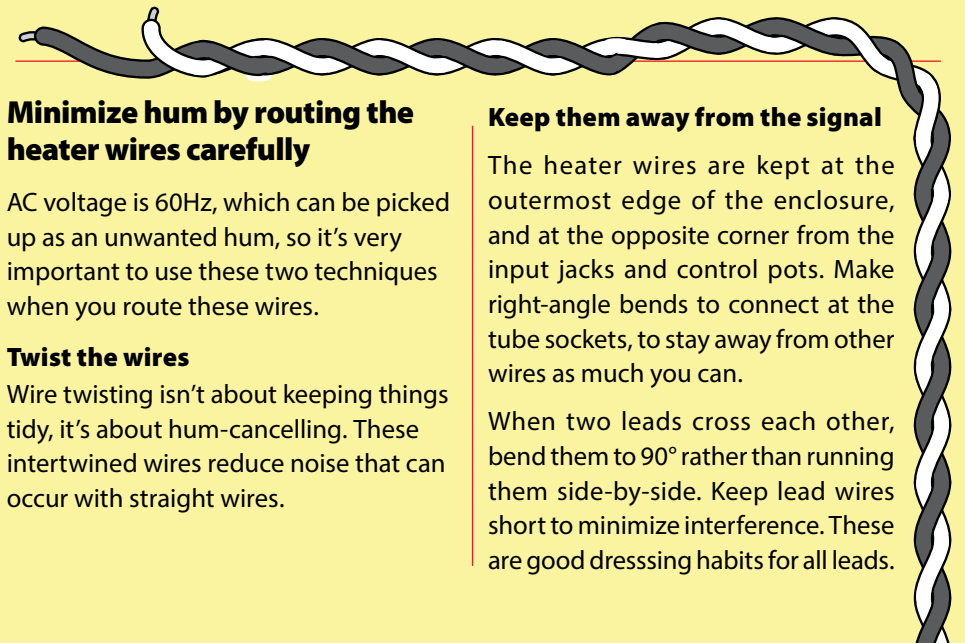

Keep them away from the signal

The heater wires are kept at the outermost edge of the enclosure, and at the opposite corner from the input jacks and control pots. Make right-angle bends to connect at the tube sockets, to stay away from other wires as much you can.

When two leads cross each other, bend them to 90° rather than running them side-by-side. Keep lead wires short to minimize interference. These are good dressing habits for all leads.

Order of build

We will build this amp in the same direction that power flows through it. With the back of the chassis facing away from you, we'll start by adding parts somewhat counterclockwise or left to right.

Initially, we'll be installing parts that connect on the top side of the amp's chassis (when the amp is in upright position). From there, we'll work our way to the front and back panels. Then, we'll connect parts that we installed earlier on the inside to the jacks, switches and other parts on the front and back panels.

Once complete, we'll run a few tests to be confident everything is correct before powering up. Be sure to have a speaker available for these tests as the speaker impedance must be present to ensure no damage to the output transformer.

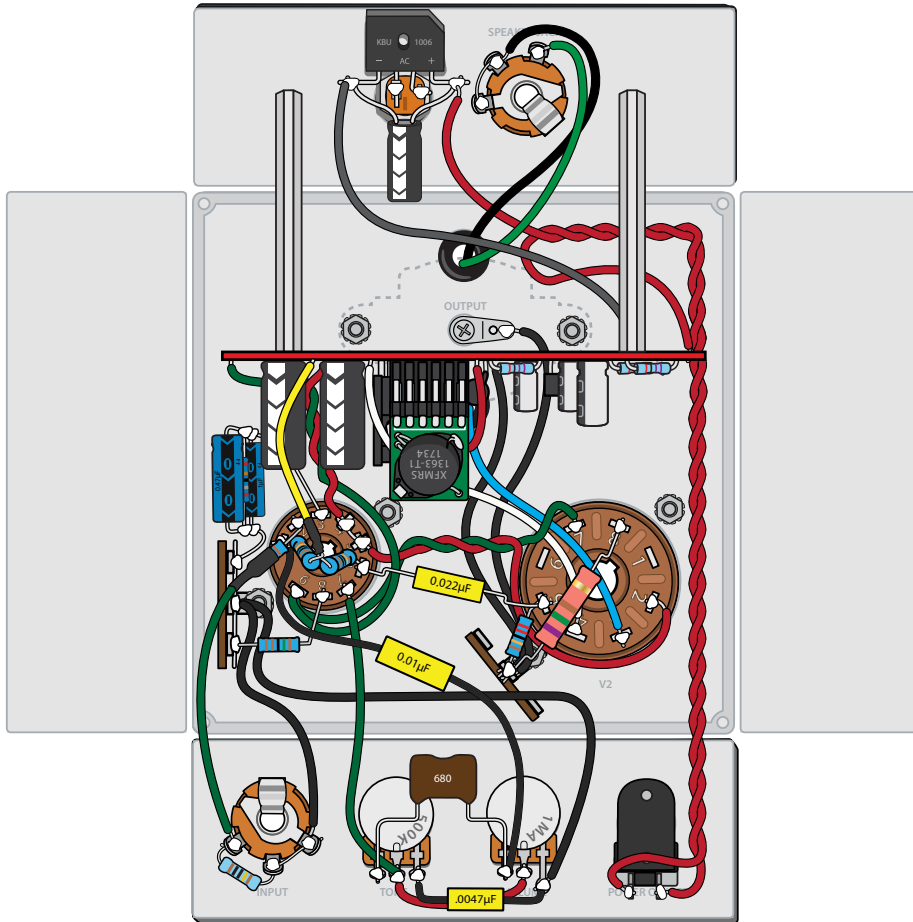

Understanding the illustrations in this guide

The majority of the illustrations in this guide are shown as an overhead view. For example, in reality the chassis is a metal box, but it is shown as flat panels in this guide.

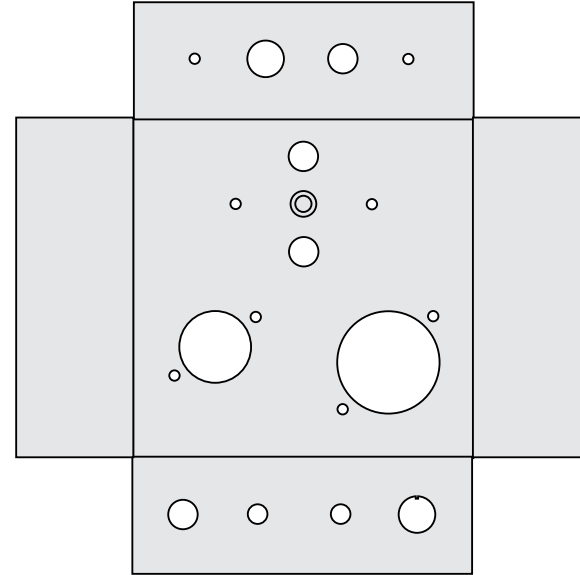

Get a handle on the chassis

Throughout this guide, directions for location and orientation of parts being installed in this amp will often be referred to based on the chassis layout. Because you'll be turning and flipping the chassis from time to time throughout this build, take a minute to acquaint yourself with the how chassis sections will be addressed.

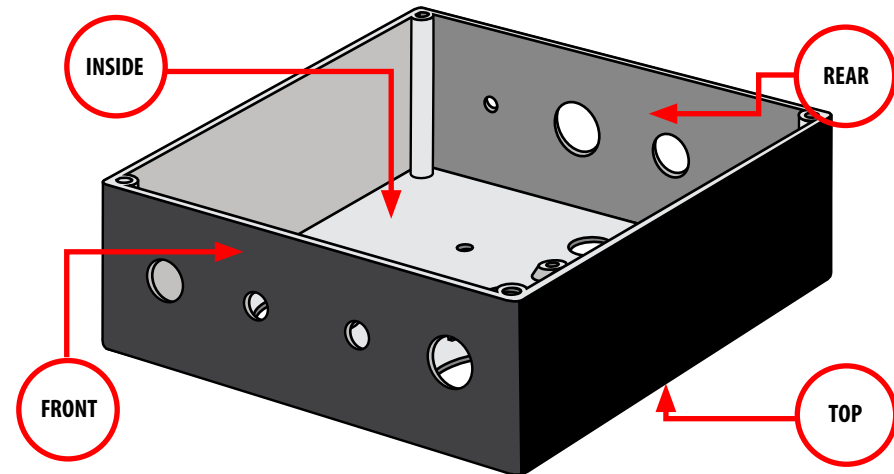

STEP BY STEP

FOLLOW THESE
STEPS AND SOON
YOU'LL HAVE AN
AMAZING AMP THAT
YOU BUILT
BY YOURSELF

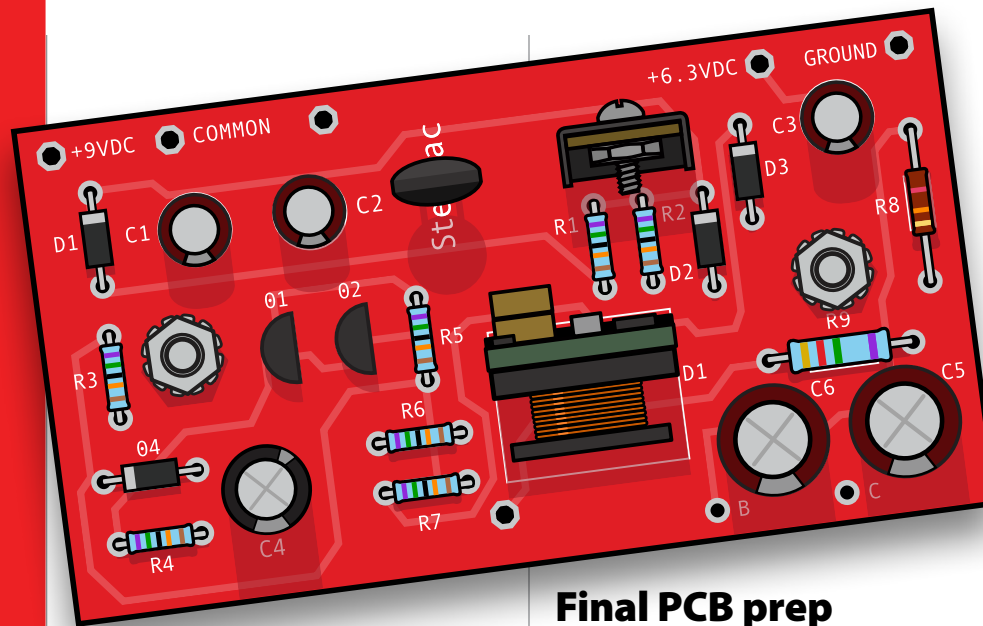

Pre-Populated Circuit Board

The Valve Factory 1 comes with a pre-populated, printed circuit board (PCB). Most of the major parts on the PCB like resistors, capacitors, and diodes have been expertly installed by StewMac's engineers. Follow the final PCB prep steps below and you will be well on your way to finishing this little powerhouse in no time!

The remaining items to install are six wires, the PCB board standoffs, and the power transformer that installs to the 12-pin socket.

This isn't your average power transformer. This little module takes the 9V power supply from the wall and ramps it up to 150VDC to power the tubes!

It is extremely delicate, so put it aside for now. You will install it later, after you finish installing the other VF1 components.

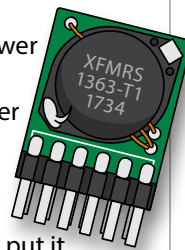

Final PCB prep

TIP! Soldering a few wires like you're about to do in the next couple of steps isn't hard, but the StewMac PCB holder (Item # 0500) makes things so much easier. Its adjustable arms hold circuit boards securely, so that you can use both hands to solder or add parts to the PCB.

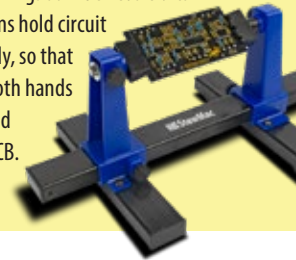

Attach PCB Wires

STEP 01

Turn on your soldering iron, grab your solder, your wire, and your PCB.

Cut a 4-1/2" piece of yellow wire and strip 3/8" of the insulation off of one end.

Cut a 4" piece of white wire and strip 3/8" of the insulation off of one end.

The PCB has a component side (the side with all the parts on it) and the back, called the solder side.

Insert the stripped end of the yellow lead through the C eyelet on the component side of the PCB and solder it in place on the solder side.

Install the white lead into eyelet B (also through the component side) and solder in place on the solder side.

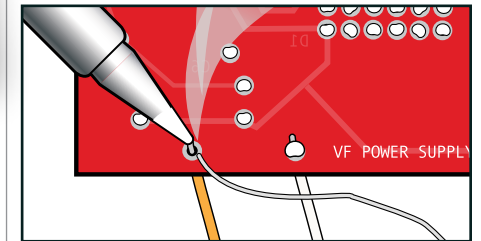

STEP 02

Find the Common eyelets in the upper left of the PCB (opposite corner of the B and C eyelets). There is one eyelet to the left of the word Common, and one to the right. Install a stripped 5-1/2" black wire in the hole to the left of the word Common. Insert from the solder side and solder the lead in place from the component side.

Install a 3-1/2" black lead into the right eyelet of the word Common. Insert from the component side and solder in place from the solder side.

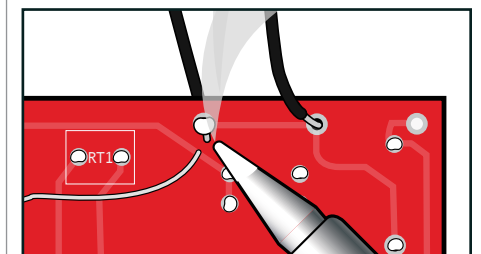

□ STEP 03

Cut and strip the ends of a 4" green lead and a 2-1/4" red lead. Make sure the leads are even at one end and then twist the pair tightly together.

Unwrap the even ends of the twisted pair enough to push through the component side and solder (on the solder side) the red lead into the +6.3VDC eyelet, and the green lead to the Ground eyelet.

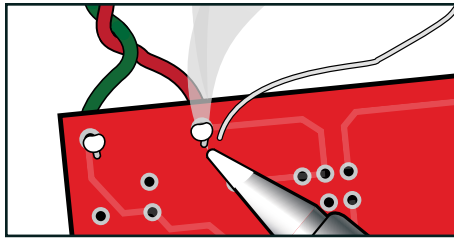

Install standoffs on PCB

The standoffs will secure the PCB to the amp chassis. The standoffs have male and female ends.

□ STEP 04

Insert the male ends of the standoffs through the solder side of the PCB and secure them with 4-40 locknuts. Ensure these are snug, but do not overtighten.

Set the PCB aside for now, we will install this to the chassis at a later time.

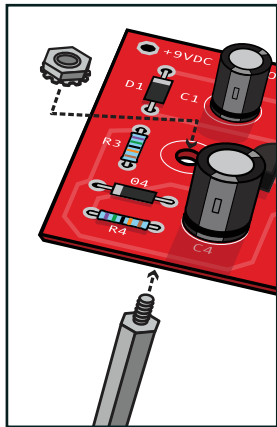

Install the top plate and grommets

□ STEP 05

Soon you will be installing components onto the top of the chassis, so it's important to be sure to install the top plate first! Align the top plate with the matching holes on the top side of the chassis. Attach the plate by pushing grommets through the two top holes as shown. These grommets will also protect the output transformer lead wires.

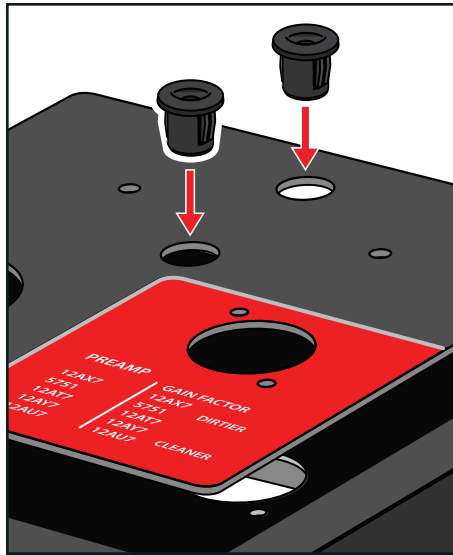

i TIP! For the vast majority of the rest of the steps in this build, you'll be adding parts to the inside of the chassis. That means the chassis will be flipped over and will rest on the faceplate you just installed. The faceplate can be scratched very easily so we recommend having a towel or bench pad (#1679) handy to lay the chassis on after installing the top plate.

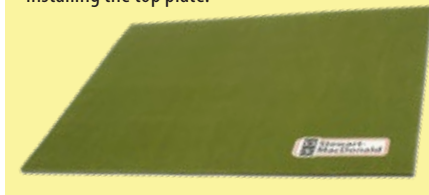

Build the power section

Prep the power jack

□ STEP 06

In order to make space for a capacitor that you will soon install, clip off the secondary positive lug on the power jack.

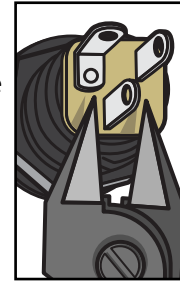

Install the back plate and power jack

□ STEP 07

Align the back plate to the appropriate holes (see diagram on page # to be sure this goes on the back of the chassis). Thread the power jack from the outside of the enclosure with the negative (bent) lug facing the top as shown above. Hand-tighten mounting nut on the inside to hold the back plate and power jack in place. Use a 14mm wrench until snug, do not overtighten to avoid stripping fragile plastic.

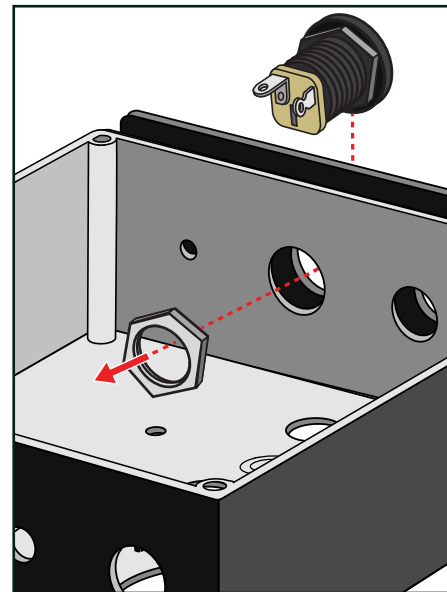

Install bridge rectifier

□ STEP 08

The bridge rectifier is a device that converts the AC voltage from the wall to DC voltage needed by the amp. Before installing, you will need to prep the outer two leads. With needle-nose pliers, bend the leads outward. The more clearance you can keep between the pins, the better.

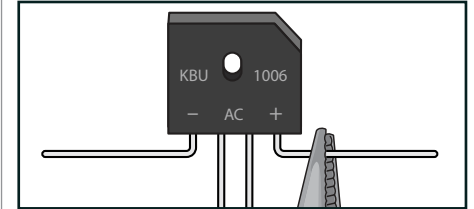

Attach the two inner rectifier leads to the power jack.

□ STEP 09

Bridge rectifiers must follow correct polarity just like electrolytic capacitors (see page 8). Note the angled/beveled corner of the rectifier; this indicates positive. Make sure to position that corner so it is facing to the right. The inner left leg will slide right into the upward facing lug on the power jack. You will need to bend the inner right leg to guide it through the sideways facing (positive) lug on the power jack. Pull the leads through their eyelets until they look like they do in the diagram below. Be careful with the power jack lugs though, they can be delicate.

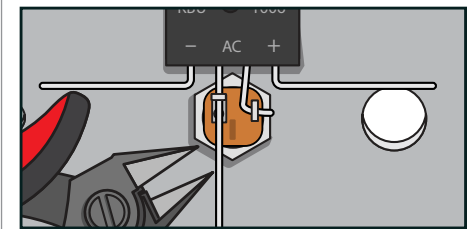

□ STEP 10

Make sure none of the leads are touching one another and then solder the two inner rectifier leads to their power jack lugs. Trim the excess rectifier leads away.

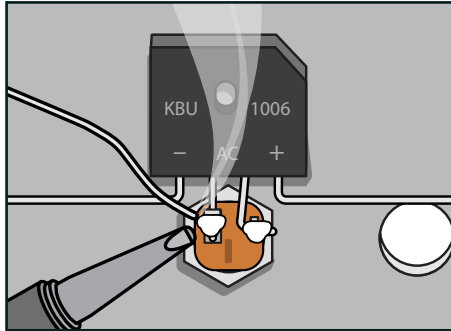

Install 2200 μ F electrolytic capacitor

Next, you will install an electrolytic capacitor to the two outside leads of the rectifier. Remember, electrolytic capacitors are polarized and need to be installed in a specific orientation. The negative lead is the shorter of the two and is also indicated by the strip on the body of the capacitor. Wrap the negative lead of the capacitor around the outer left lead of the rectifier. The positive lead is the longer of the two and needs to be wrapped around the bridge rectifier lead farthest to the right.

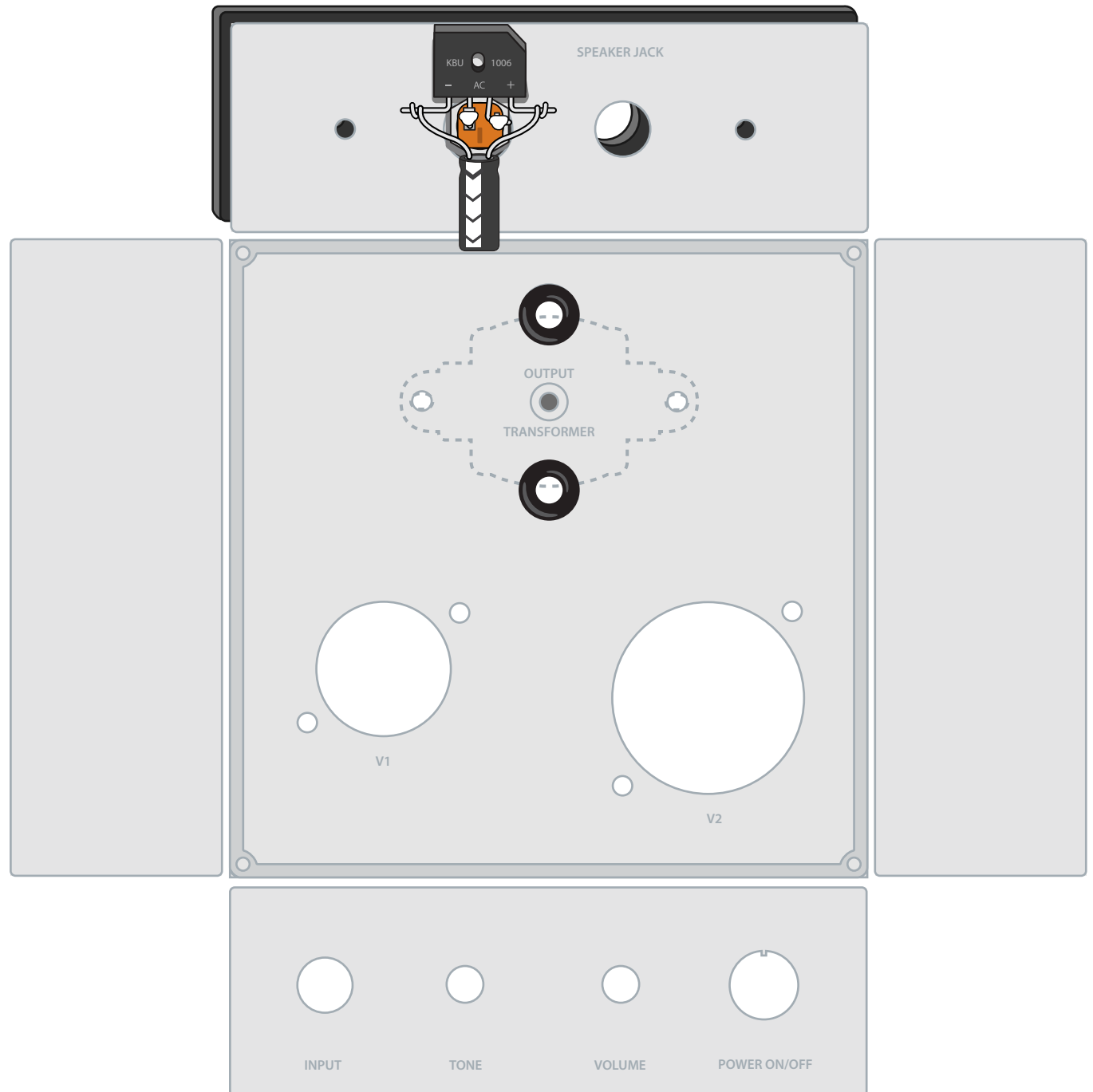
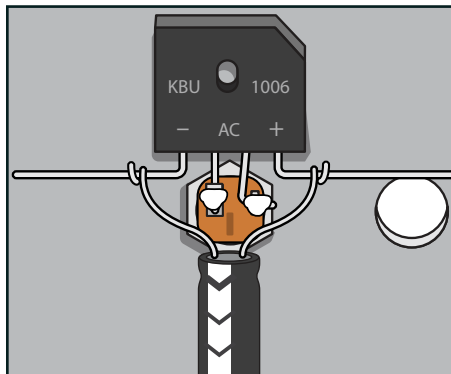

Solder outer two leads of the bridge rectifier to the capacitor

□STEP 11

Make sure none of the capacitor leads are touching the lugs on the power jack. Also make sure the leads of the capacitor are wrapped tightly around the rectifier leads. Once you have double checked your work, solder those wrapped leads using as little solder as possible and trim away any excess lead wire. We will be soldering lead wires to these points soon, so it is ideal to use as little solder as you can to hold these parts together. Once the solder joints have cooled, gently bend the body of the capacitor down into the corner of the chassis, as shown in the diagram.

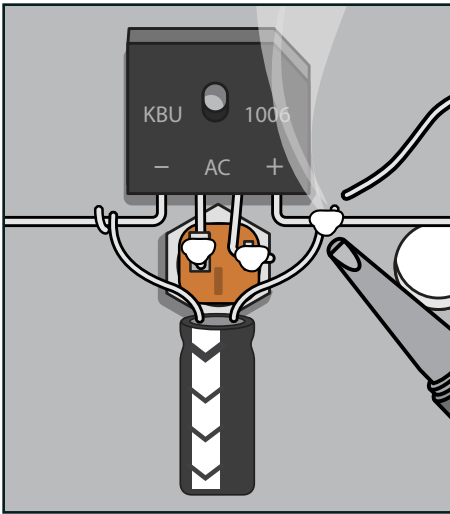

Install ON/OFF switch

□STEP 12

The power switch has a hex nut, flat washer, and round knurled dress nut. Remove the dress nut and washer from the switch. Tighten the hex nut all the way down to the switch, if it isn't there already, and then give it three rotations away from the body of the switch. This will set the perfect depth of the switch, with only a few threads exposed once it is fully installed.

□STEP 13

Locate the front faceplate and align it with the front chassis holes. The StewMac logo should be closest to the cover plate. Guide the threads of the switch through the back of the hole labeled "ON". Make sure the lugs are facing the opening of the chassis. Add the flat washer first and then thread the dress nut onto the switch. Just get it finger tight for now.

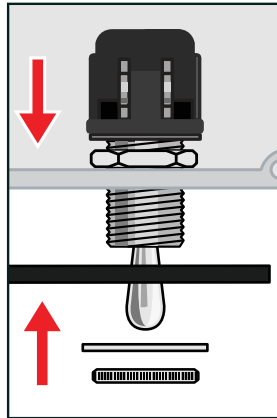

i TIP! You have to use caution when tightening down this nut the rest of the way. It is very easy to scratch the faceplate if you just try to use pliers. We recommend using our Adjustable Toggle Switch Wrench (#1699) or Soft Touch Pliers (#1719). If you have to use regular pliers, we recommend lightly applying masking tape to the surface of the faceplate while you are tightening the nut down.



□STEP 14

Measure and cut two 7.5" lengths of red wire and twist them together. Expose 1/8" of wire at both ends of each lead.

□STEP 15

Solder the leads of one end of the twisted pair to the lugs on the power switch, it doesn't matter which end goes to which lug. Carefully dress the pair of red twisted wires along the bottom of the chassis, headed toward the power jack.

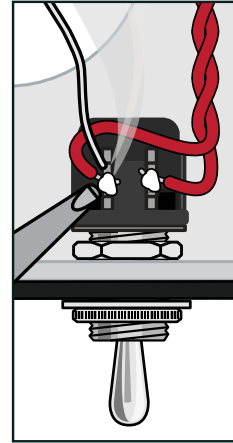

Install speaker jack

□STEP 16

Next we're moving to the back panel to install the speaker jack. The speaker jack has a hex nut, flat washer, and toothed locking washer. Remove the hex nut and flat washer from jack. Leaving the toothed locking washer in place, guide the threads of the jack through the back of the hole labeled "Speaker". Make sure the lugs are facing the opening of the chassis. Add the flat washer first and thread the hex nut onto the jack. Use a 1/2" socket to tighten the nut all the way down.

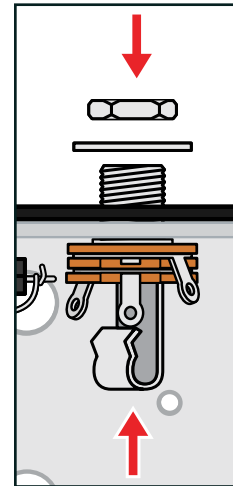

Install output transformer

□STEP 17

Feed the wires from the output transformer so the green and black wires go through grommet closest to the rear panel. The red and blue wires go through the remaining grommet.

Use the provided 3/8" 6-32 machine screws and locknuts to affix the output transformer to the top of the chassis with the locknuts on the inside.

Install output transformer secondary lead wires to the speaker jack

□STEP 18

Starting with the green lead from the output transformer, measure so there is enough length to reach the tip lug leaving a bit of room to dress without blocking the jack. Solder this into place. Then measure the black lead from the output transformer so there is enough length to reach the tip shunt lug (middle) and jumper to the sleeve lug. Strip 1/2" of the black insulation from lead, and solder in place as shown. As these wires are stranded, we recommend tinning the stripped portion with solder prior to soldering at the lugs to help these insert in the lug holes.

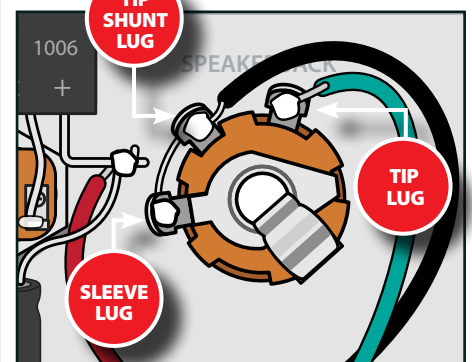

Install positive rectifier wire

□ STEP 19

Locate one of the two loose ends of the twisted pair of red leads coming from the ON/OFF switch, it does not matter which. Solder this wire to the positive bridge rectifier lead along with the positive lead of the filter capacitor. Leave the other loose end of the twisted pair of red leads unsoldered for now.

Prep one of your terminal strips

□ STEP 20

Next, you will prep just one of your terminal strips. Use the core of 1" of green pushback wire to connect the three lugs of one of your terminal strips. Solder this in place at each lug. Trim ends. Do not clog the holes, as future connections will go there.

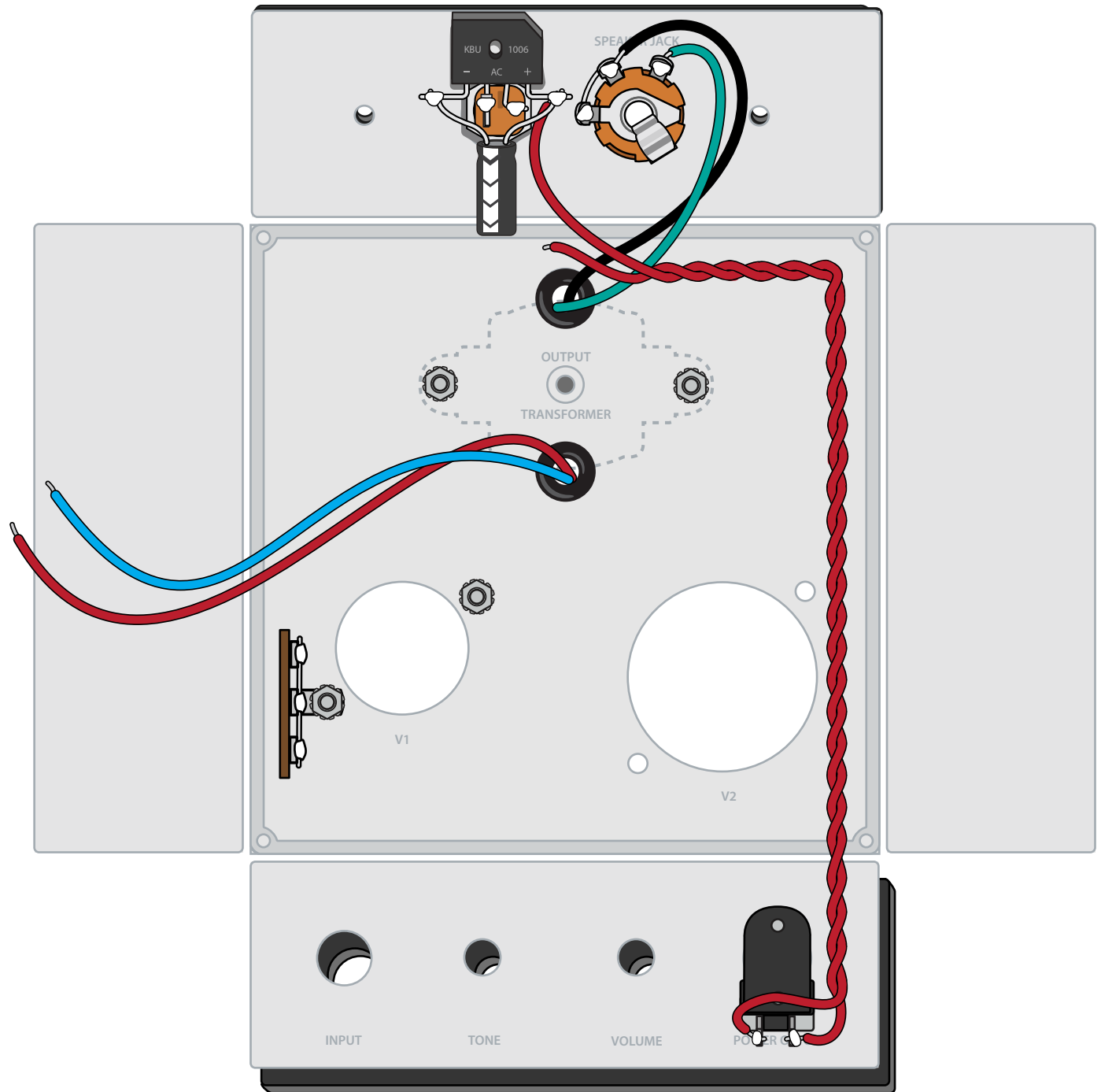
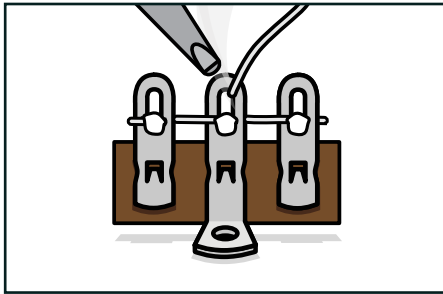

Install V1 preamp tube socket and terminal strip

With a pair of needle nosed pliers CAREFULLY twist pins 4 and 5 of the 9 pin preamp tube socket so that their eyelets face each other.

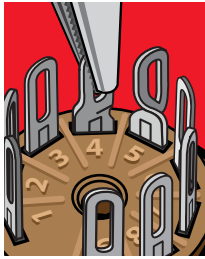

□ STEP 21

Feed the preamp tube socket through the smaller of the two holes from the outside of the chassis. Ensure the socket is oriented so that pins 4 and 5 are facing more towards the DC and speaker jacks.

Next, insert a 4-40 screw from the top of the chassis into the hole closest to the 4/5 pins and secure it with a locknut on the inside. Taping the screw on the outside helps to hold it in place while attaching the locknut.

□ STEP 22

Next, insert another 4-40 machine screw through the preamp tube socket closest to pin 9. Before adding the locknut, thread the grounding terminal strip you just prepped to the 4-40 screw and tighten the locknut so the strip is making solid contact with the chassis.

□ STEP 23

Check these connections by setting your multimeter to test continuity and touching each of the terminal lugs with one meter probe and any unpainted part of the inside of the chassis with the other probe. You should find all lugs show continuity with the chassis.

□ STEP 24

Cut a 6-1/4" and 2-1/4" length of black lead and expose 1/8" of wire on both ends. Solder one end of both of these leads to the center lug of the V1 terminal strip. Dress the leads to the lower left corner of the chassis.

V2 power tube socket and terminal strip install

□ STEP 25

From the outside of the chassis, insert the power tube socket so that pin 1 is oriented toward the right side of the chassis, between 2 and 3 o'clock. Insert a 4-40 screw through the hole closest to pin 1 and attach a locknut on the inside of the chassis. Insert another 4-40 screw, along with the remaining terminal strip (no buss bar on this one) to the second hole of the socket. Be sure the terminal strip is angled as shown before tightening locknut.

Install ground solder lug

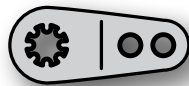

□ STEP 26

Install the included ground solder tab to the threaded internal chassis standoff with the 6-32 1/4" machine screw. Make sure it's facing to the right as it will cause less wire congestion later.

Cut a 3-1/4" length of black wire and strip 3/8" off of each end. Solder one end of the wire to the ground lug. Dress this wire to the floor of the chassis and towards the V2 terminal strip. Wrap the exposed end of this lead through the center lug of the V2 terminal strip. Other leads will also eventually connect to this same lug so don't solder in place at this point.

Now that we have all the components installed to the floor of the chassis, we can start building up.

V1 cathode bypass assembly and install

□ STEP 27

Now you are going to make your 1.47μF preamp cathode bypass as a subassembly. For this, you'll need three components:

- 1.8K resistor
- 1μF capacitor
- .47μF capacitor

It is important to note that your cathode bypass is comprised of polarized electrolytic capacitors, so you will need to double check that you have them appropriately oriented with the cathodes connecting to your V1 terminal strip, and the positive leads connecting to V1 tube socket pin 3.

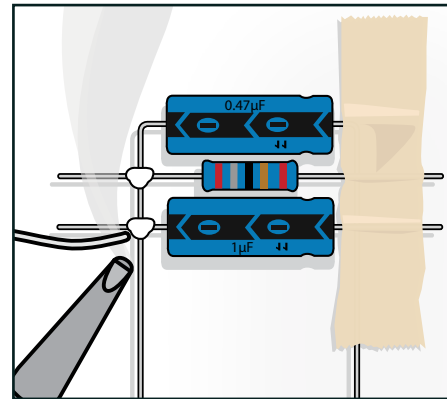

TIP! When building the V1 cathode bypass subassembly, first bend the leads of the .47μF capacitor to a 90 degree angle, then lay it on a flat work surface. Tear off a 2" piece of tape and have it ready. Next layer the 1.8K and 1μF capacitor on top of the leads of the .47μF capacitor and tape one side of the leads to your work surface. With the parts secured, solder the untaped leads of the resistor and capacitors. Once the solder has cooled, remove the tape and solder the the leads on the other side. When those leads have cooled, trim any excess leads.

□ STEP 28

Connect the positive end of your assembly to pin 3 (cathode) on V1. The negative end attaches to the terminal strip lug closest to the rear panel of the chassis. Measure pin 3 with your multimeter to assure continuity.

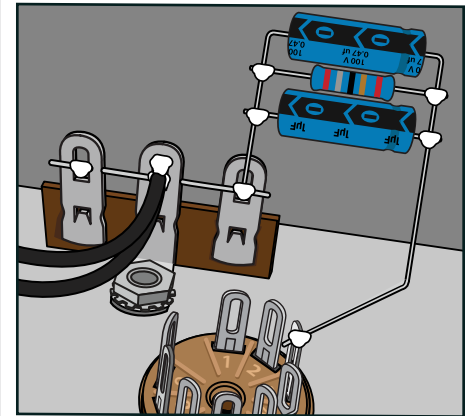

Input jack subassembly

□ STEP 29

For ease, we're going to prep the input jack before installing it into the chassis. To do this, affix the jack to the outside of the chassis (oriented as shown) using the same mounting hole.

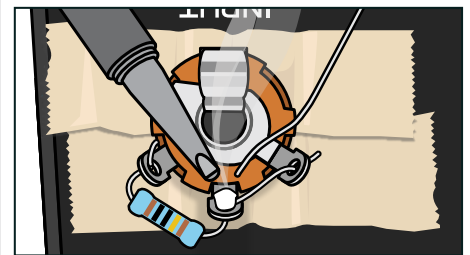

You can use tape around the jack hole to protect the faceplate from solder debris and flux. Run a 1M resistor between the left and center lugs of the input jack. Use the right lead to jumper the center and right lugs of the input jack. Solder the resistor in place at the center lug of the input jack.

□ STEP 30

Solder a 1-1/2" green lead to the left lug of the input jack, along with the other end of the 1M resistor.

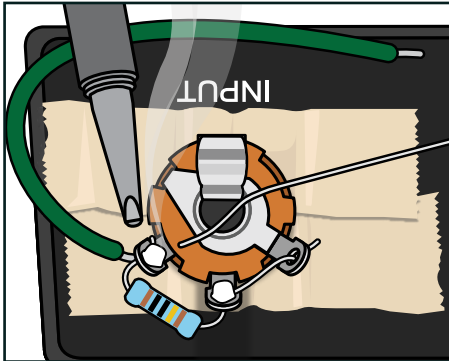

Install input jack

□ STEP 31

Guide the input jack through its chassis hole with the provided lock washer positioned between the chassis and the jack, with the center lug facing up. Secure with the nut and flat washer. Find the 2-1/4" black lead coming from the center lug of the V1 terminal strip and solder it to the right lug of the input jack.

Connect V1 and V2 heaters

□ STEP 32

Cut and strip 3-1/2" inches of green and red wire and twist them together tightly. Solder one end of green wire to pin 7 of V2 and the same end of the red wire to pin 2 of V2.

□ STEP 33

Next, to help minimize hum, dress the wires against the inside top of the enclosure toward V1. Connect the green lead to pin 9 of V1 and the red lead to pins 4/5 of V1, do not solder yet.

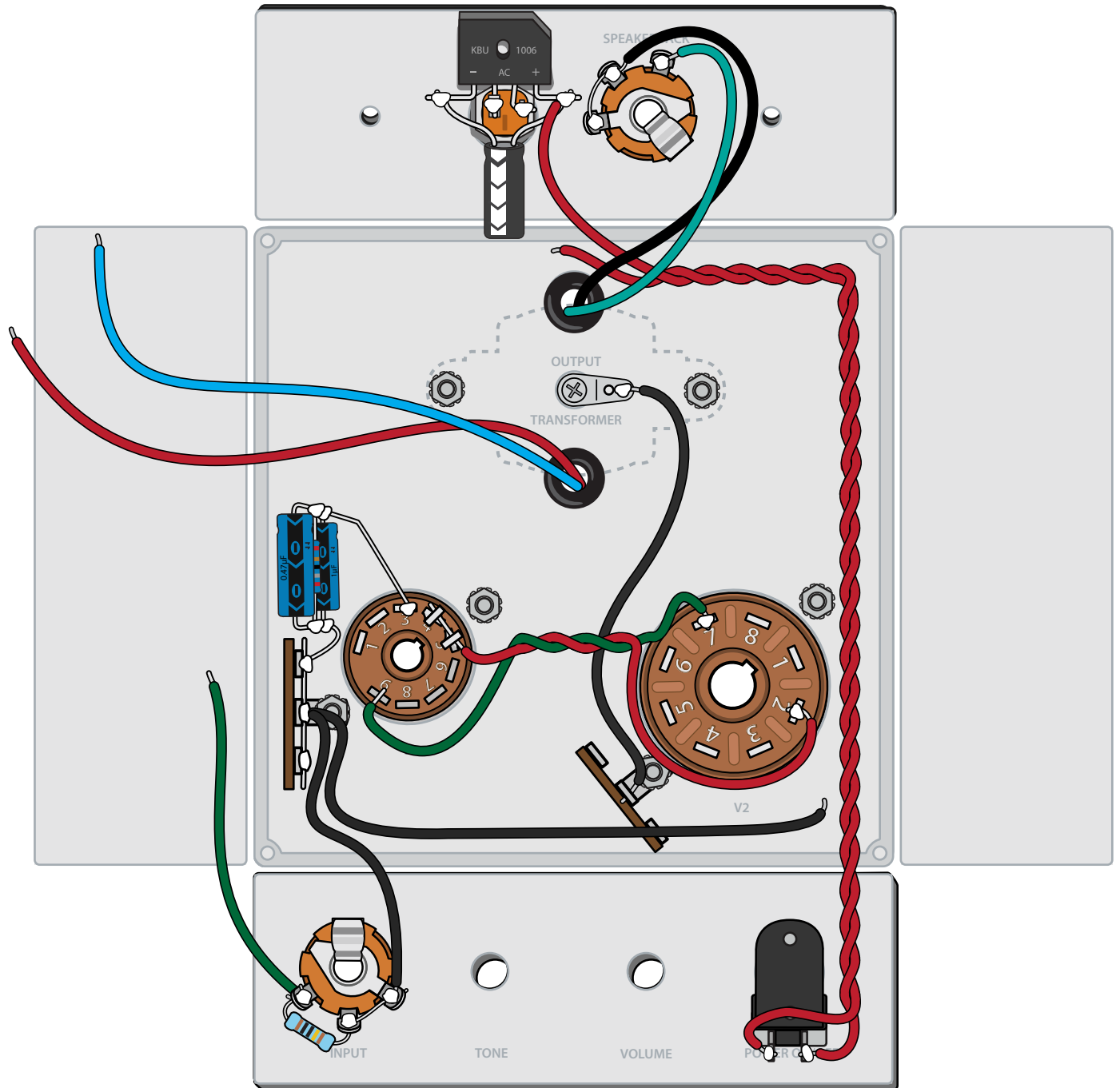

Install PCB

□STEP 34

It's time to mount the prepped power supply PCB by feeding the two 4-40 3/8" machine screws through the mounting holes on either side of the DC and speaker jacks and threading them to the standoffs already installed to the board. Before you fully tighten down the screws, you should solder the remaining ON/OFF switch lead and your bridge rectifier where it connects to the negative power filter lead.

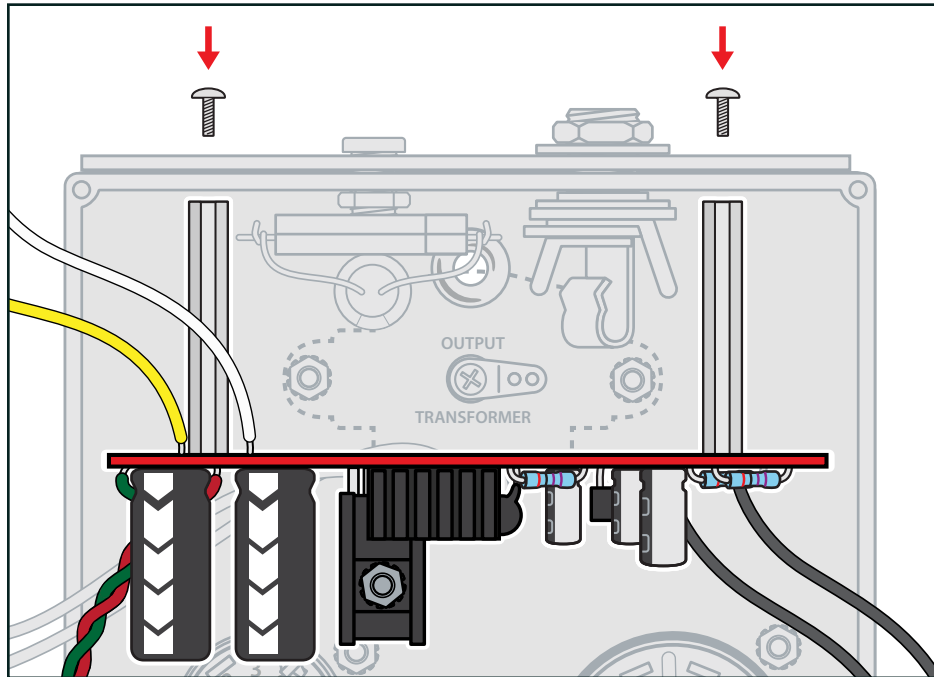

□STEP 35

Take care to arrange the wires already in the chassis so that they are not pinched or damaged by the PCB install. The output transformer primary leads should be dressed towards the tube sockets and the secondary leads that are soldered to the speaker jack should be clear of the standoffs.

□STEP 36

Once the PCB standoffs are roughly in place, solder the uninstalled red lead from the twisted pair coming from the power switch to the PCB 9VDC eyelet. Run the lead through from the underside of the PCB and solder from the component side.

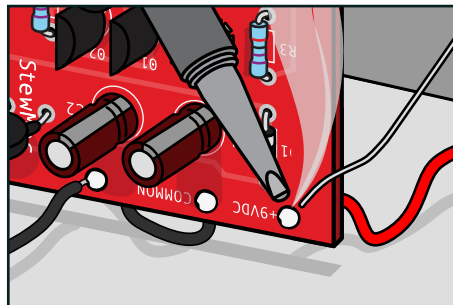

□STEP 37

Trim to length, strip, and solder in place the 5-1/2" black lead coming from the underside of the Common PCB eyelet to the negative bridge rectifier lead along with the filter capacitor negative lead.

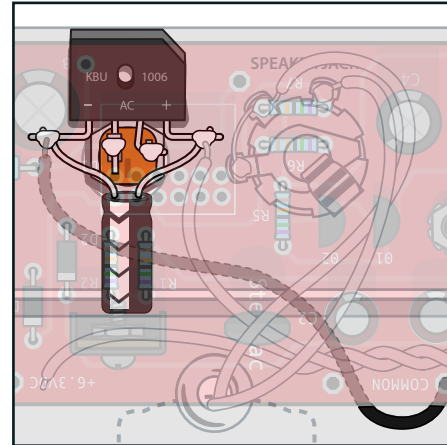

□STEP 38

Next, dress the 3-1/2" black lead coming from the component side of the PCB towards the V2 terminal strip. You can dress this lead under or over the twisted heater wires. Trim, strip and connect the end of the black lead to the center lug of the V2 terminal strip, along with the chassis ground lead. Do not solder this connection yet, there are still two more components to add here.

□STEP 39

Locate the red and green twisted pair of leads connected to the PCB. Run the red lead to V1 pin 4/5 and solder in place along with the red heater wire coming from V2. Connect the green wire from the PCB to V1 pin 9, solder in place with the green heater lead coming from V2.

Install output transformer primary leads

□STEP 40

Before we get started populating the passive components to our tube sockets, go ahead and trim, strip, and solder the blue output transformer lead to pin 3 of V2, and the red output transformer lead to the component side of the last remaining PCB eyelet located near R7. Solder the red lead from the solder side of the PCB.

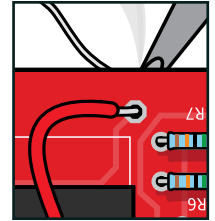

V1 and V2 components installation

□STEP 41

Install 1.5K resistor across the V1 terminal strip lug closest to the input jack and V1 pin 8.

□STEP 42

Slide a 1" piece of 1/4" diameter heat shrink over the green lead soldered to the left lug of the input jack. Next, cut one end of a 39K resistor down to about 3/4" long and solder it to the loose end of the green lead keeping the shrink away from heat. You can do this by bending hooks into both leads, or you can solder together flush. Once the joint has cooled, move the heat shrink over the exposed leads and heat to shrink with a heat source. Feed the exposed end of the resistor through pin 2 lug of the V1 socket and solder in place.

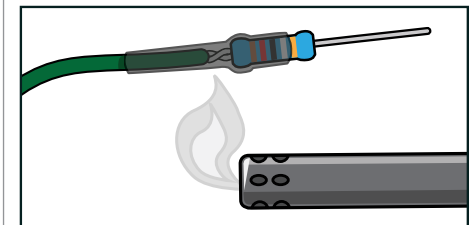

□STEP 46

Using the 1/16" heat shrink, insulate both leads of the .01µF capacitor, leaving 1/4" exposed on both ends.

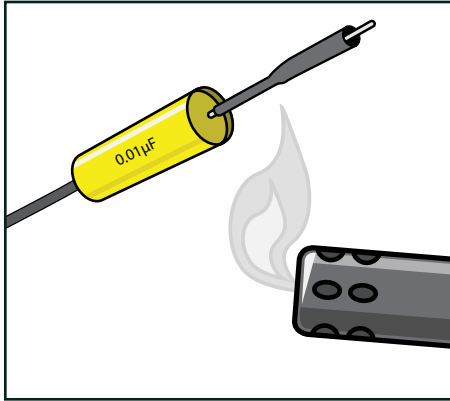

Install one end of the capacitor to V1 pin 1 and solder in place along with one of the unsoldered 100K resistors.

□STEP 47

Solder one end of the 220K resistor to the top eyelet of pin 5 of V2. Run the other end to the center lug of the V2 terminal strip, do not solder this yet.

□STEP 48

Solder the white lead from PCB to V2 pin 4.

□STEP 49

Solder one end of the 750Ω metal oxide resistor to V2 pin 8 (take care not to singe the blue output transformer lead soldered to Pin 3). Run the other end to the center lug of V2 terminal strip, solder all four leads that are at this location.

□STEP 50

Slide a 1/2" length of 1/4" diameter heat shrink onto the yellow lead coming from the PCB, leave this aside for now and out of the way of solder heat. Solder the yellow lead coming off the PCB to the twisted end of the 100K resistor pair.

□STEP 51

Once the solder has cooled, slide the heat shrink over the connection and heat the tubing to fit.

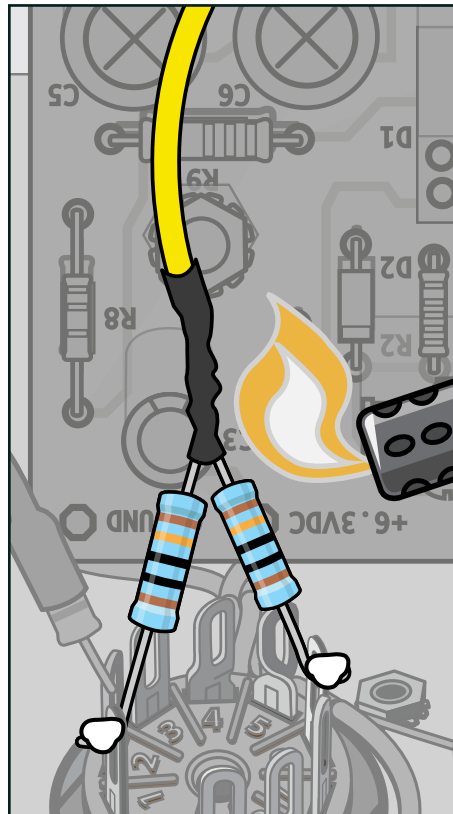

Install pots and pot components

Install two pots

□STEP 52

The pots included in this amp kit will still have metal indicator pins parallel to the pot shafts that you'll need to break off with a pair of pliers before you can mount them to the chassis.

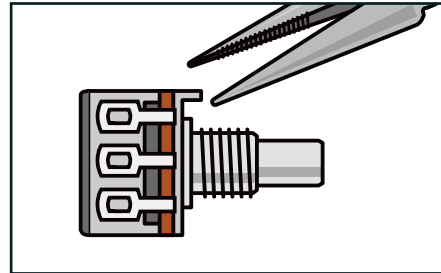

□STEP 53

Install the A1M pot in the Volume position, and the B500K pot in the Tone position. Use a 10mm nut driver to secure.

Connect the Volume pot to V1 terminal strip

□STEP 54

Next, bend the right lug of the Volume pot (when looking at the master diagram shown on the right) upwards in order to allow for the clearance needed to install the remaining components. Strip the end of the black lead coming from the V1 terminal strip and connect it to this pot lug, but do not solder yet.

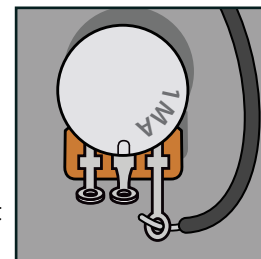

□STEP 55

Run the green wire coming from V1 pin 7 to the center lug of the Tone pot. Do not solder yet.

□STEP 56

Measure, cut, strip and install a 1-1/2" red jumper from the center lug of the Volume pot to the center lug of the Tone pot, along with the green jumper coming from V1 pin 7 already there.

□STEP 57

Locate the unsoldered end of your .01µF capacitor coming from V1 pin 1 and wrap the exposed end through the left lug of the Volume pot, but do not solder this connection yet.

□STEP 58

Bend the leads of the 680pF ceramic capacitor. Solder one end of the 680pF ceramic capacitor to the left lug of the Tone pot. Run the other end of this capacitor to the left lug of the Volume pot and solder in place at the left lug of the Volume pot, along with the unsoldered end of your .01µF capacitor coming from V1 pin 1.

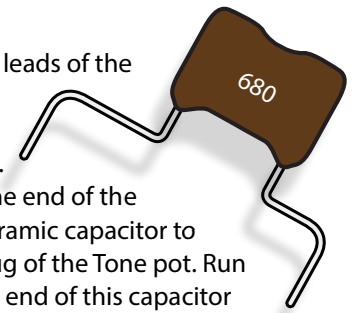

□ STEP 59

The last passive component will be the .0047 μ F capacitor.

i NOTE: Like with the 0.01 μ F that you applied a small amount of 1/16" diameter heat shrink tubing to in an earlier step, we recommend doing the same thing to the .0047 μ F you're about to install. While this isn't a critical step it is one that will assure the leads are insulated from contact with other parts.

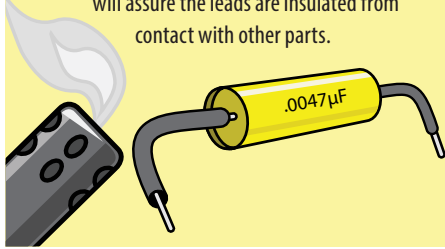

You will solder one end of this capacitor to the right lug of the Tone pot, and the other end to the right lug of the Volume pot, along with the black lead coming from the V1 terminal strip.

Attach power transformer

□ STEP 60

The very last step before testing is installing the power transformer. Simply and carefully snap the module into the PCB with the mini circuit board and copper coil facing up.

i NOTE: The power circuit is designed to let the tubes warm up, so don't panic if your amp doesn't seem to be working immediately when you flip the power switch on.

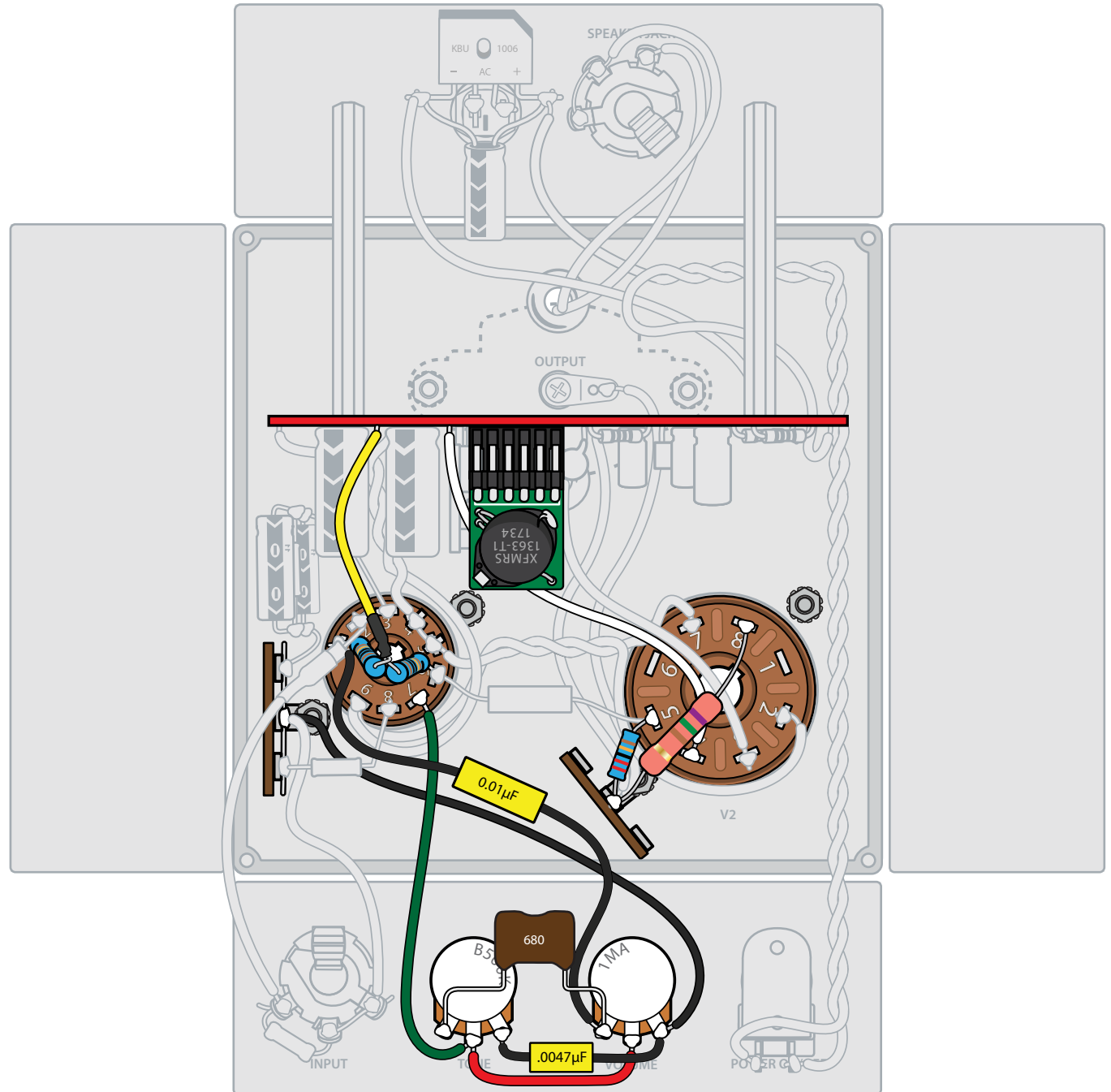

Testing

□ STEP 61

Before testing, we want to have everything plugged in. Install the 6V6 tube into V2 taking note of the alignment notch on the bottom of the tube and install the 12AX7/ECC83 preamp tube into V1 taking note of the missing pin and receptacle in the socket.

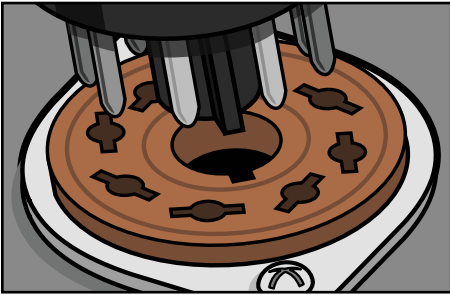

Plug the speaker output on the back of the amp into an appropriate speaker cabinet with 4 or 8 ohms of impedance. It is important to use a speaker cable and not a guitar cable. Speaker cables are not shielded and use a heavier gauge wire to carry a more powerful signal from your amp to your speakers. Also, go ahead and plug in a guitar and cable into the input jack and then attach the power adapter to the jack and plug into an outlet.

i NOTE: Connecting a proper speaker and speaker cable before powering on the amp for any reason is a must. Not doing so would apply power to the circuit without the proper load or impedance from the speaker. Without this impedance to absorb the energy, the output transformer can create dangerously high voltage spikes resulting in excessive voltage buildup that could cause damage to the output transformer, the power tubes, or other components.

Make sure the volume knob is turned low but not completely down and flip the power switch to ON looking for smoke or unusual smells. If anything seems unusual, disconnect the power immediately and carefully review all your connections. Otherwise, you should start to hear sound coming through in about 15-20 seconds as the tubes have time to warm up.

Adjusting the volume as necessary to confirm, if no signal is present, power off and review your connections. As previously mentioned, a Snuffer Stick is not required to dissipate the charge in the capacitors, however, be mindful of the two 22uF capacitors on the PCB by the yellow wire as they can hold a charge at this point.

If no issues are found, grab your multimeter and test a few points to further ensure operation. Start by connecting your multimeter's negative lead to ground by clipping one end of a test lead to the negative lead of the multimeter and the other end of the test lead to either the Sleeve or Tip Shunt Lug of the speaker jack where the black output transformer wire is soldered.

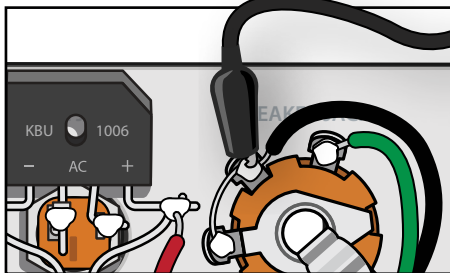

V Turn on your multimeter to test for DC for the appropriate ranges as needed. **Keep one hand behind your back when probing a component so you can't be a path between the voltage and ground which could send a dangerous charge through your heart.**

- 1 With your other hand, take the positive multimeter test lead and attach it to V2 Pin 2 where you should read 6.3 VDC.
- 2 Next, check V2 Pin 3 where the blue transformer wire is attached and you should read 125-130 VDC.
- 3 This can also be checked on the solder side of the PCB where the yellow wire is connected.
- 4 Then, check V2 Pin 4 where the white wire from the PCB is attached and you should read 145-150 VDC.
- 5 This can also be checked on the solder side of the PCB where the white wire is connected. If any readings are drastically off, power off and re-check all connections as necessary.

i NOTE: Please note that these test values were verified with a 120 VAC power source. If your results vary, you may want to check your wall voltage with your multimeter. If you are lower than 120 VAC, you will see slightly lower results while a higher VAC will result in slightly higher readings.

If the amp is stable and your tests match the voltages specified, it's time to rock! Play for a few minutes and test to ensure the amp is fully functional. If you run into any issues, be sure to check all of your connections and review the build as necessary. If needed, don't hesitate to reach out to our Customer Service department as our Technicians are standing by to help troubleshoot.

Otherwise, congrats on the build and now it's time to put the finishing touches on!

Closing time

□ STEP 62

With testing complete, it's time to add the rubber feet to the bottom plate and then attach that plate to the bottom of the amp chassis with the provided screws.

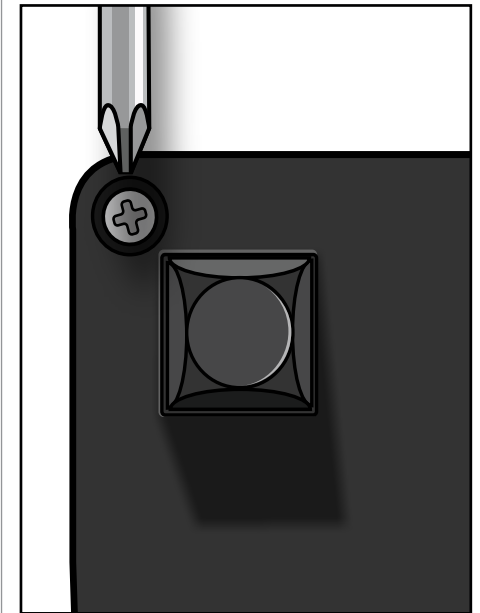



With the amp in the upright position, turn the pot shafts of the Tone and Volume controls to the left as far as they can go. Loosen the set screw in the knobs enough until they will slide onto the pot shafts. Turn the knobs until the dot and slash point towards the “V” in Volume and the “T” in the word Tone. Tighten the set screws to secure the knobs.

Time to experiment! As you’ll see on the preamp plate on your amp, various tubes can be used to provide a myriad of tones. We recommend trying these out to get the most of your amp and tone. See the next few pages for more details on these tube options and how they can color and shape your tone. In addition, as this amp will accept 4 and 8 ohm speaker cabinets, there are near endless combinations to try and explore. Enjoy!

i NOTE: These tubes get HOT!

When you are swapping out the preamp tube, power down for a few minutes to ensure the tubes are cool. Only change the tubes with the amp turned off and unplugged from the wall.

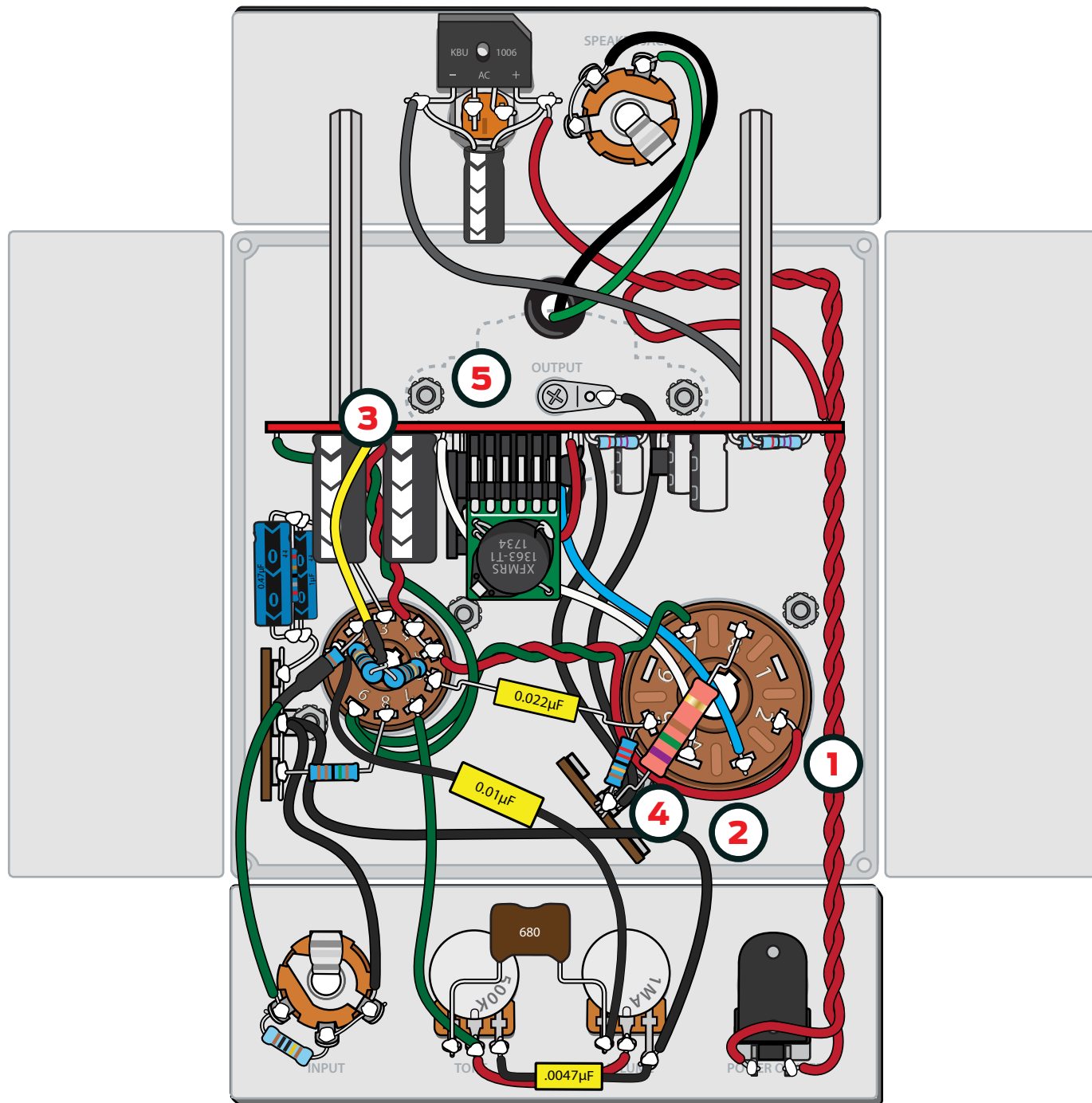

Completed Drawing

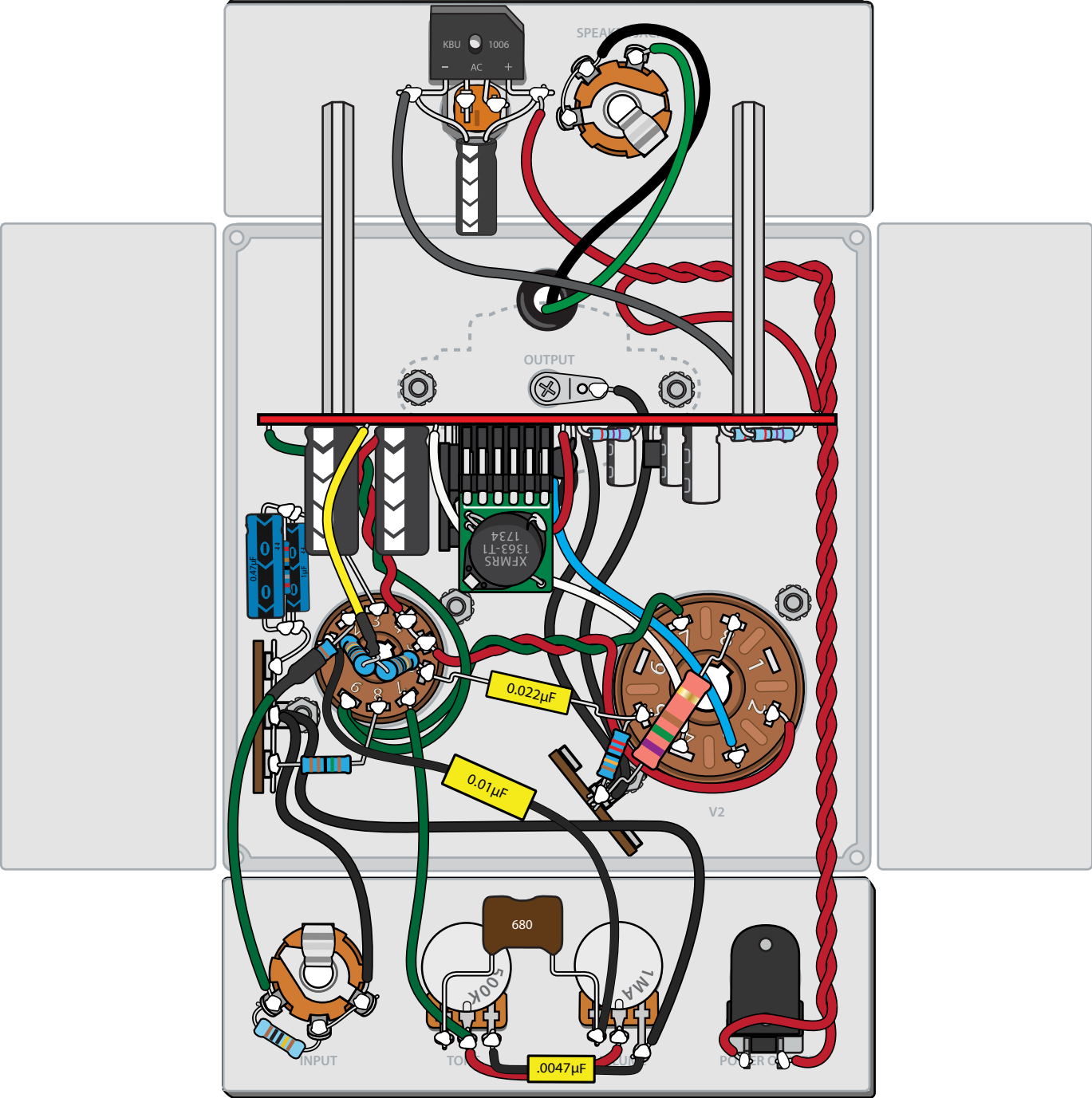

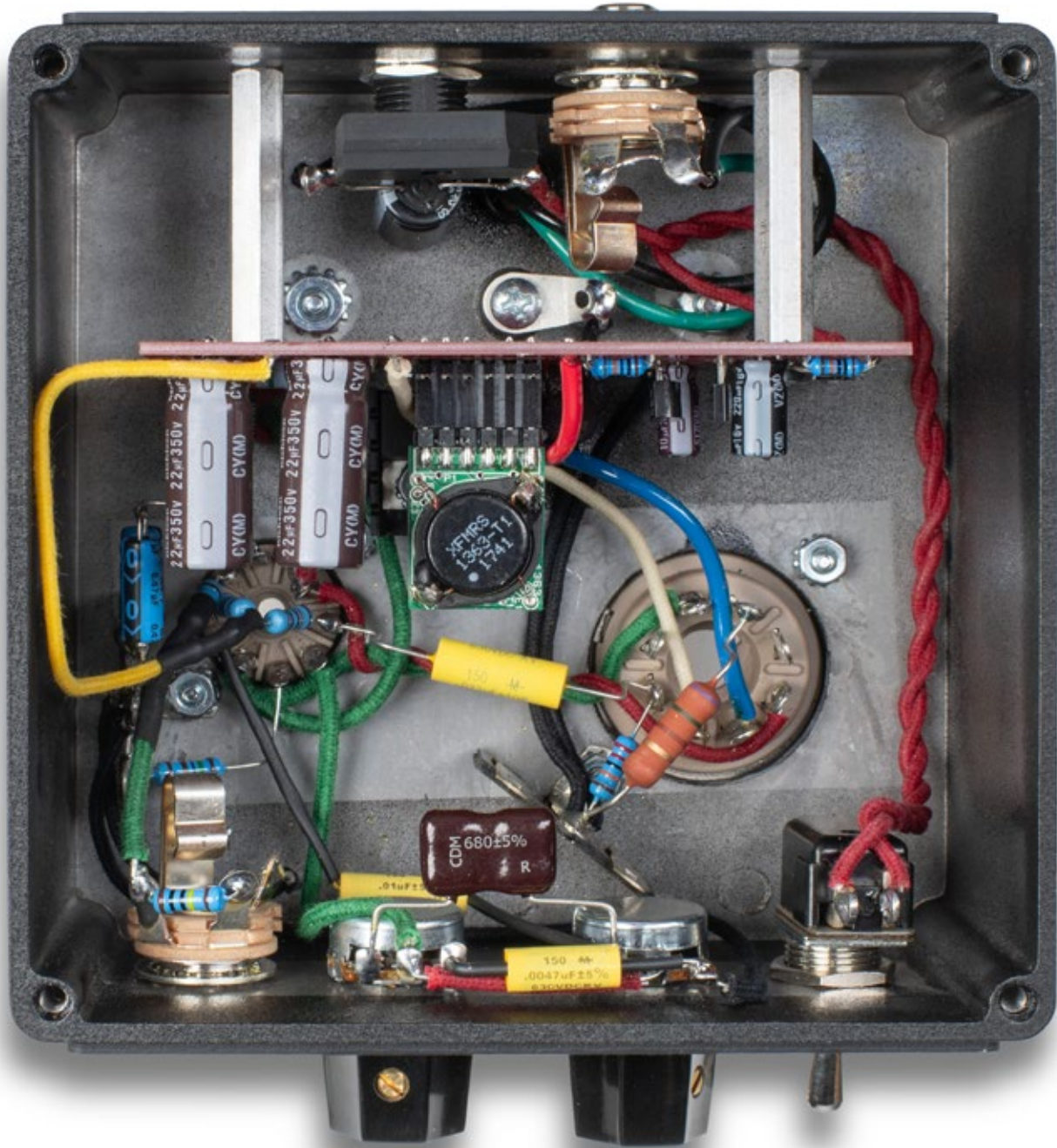

Tubes: Some insight on what goes on inside

Inside the glass structure that makes up a tube, you'll find several components, one being a filament. This is the part that glows when electric current flows through it. The heat that comes off of the filament causes the cathode inside the tube to release negatively charged electrons. Those negatively charged electrons are attracted to the positively charged anode called the plate. Between the cathode and plate is a grid. The grid carries the AC signal from a guitar's pickup and allows the flow of electrons from the cathode to plate inside the tube, amplifying the signal.

Preamp and power tubes

Preamp tubes start amplifying the signal coming from the guitar up to line level. The more gain you give the first preamp tube, the more preamp distortion you'll get. The second preamp tube is the phaser inverter. This tube splits your signal in two, inverts one of them, and sends them both to their respective power tubes. The power tubes work with the output transformer in a "push-pull" configuration to send the two halves of your signal coming from the phase inverter, now amplified to speaker level, through your speaker.

It's said that much of a tube amp's "feel" comes from the power tube. By cranking this section of the amp, you're adding more of that natural tube distortion – creating more harmonic overtones, more touch-responsiveness, and adding that warmth these amps are famous for.

Customize your tubes and your tone

Now that you have a better understanding of how preamp and power tubes work, let's talk about the sound they can create. In general, at low volumes, you can pretty much get tone out of any tube – but once you start cranking up the volume, you start to hear a difference. The beauty of the VF18 is you can select the perfect tubes to customize your amp, based on the type of music you play, and where you play it. The chart below is a great start to help you select the right tubes. From smooth jazz to hard rock and beyond, experimenting with preamp tubes can help you create a sound you never thought possible, and then claim as your own.



12AX7 [100 GAIN]
Included in kit
7025 [100 GAIN]
5751 [70 GAIN]

The 12AX7, 7025, and 5751 are the most commonly used high gain factor tubes. The 5751 and 7025 are said to be higher-rated for lower noise, but hearing a distinct difference isn't easy. These high gain tubes are all guts and glory. They have the least amount of headroom, which means they'll break up the fastest. If the AC/DC hard rock sound is what you're after, these are your tubes.

12AY7 [60 GAIN] The 12AY7 is much like the 12AT7, but more headroom, so it's perfect for getting more into overdriven blues to edge of breakup clean tones.

12AT7 [60 GAIN]

The 12AT7 is probably the most versatile tube. It can do hard rock/distorted tones, but also has more headroom, so it can get louder without breaking up as much as the 12AX7-type tubes. This tube pulls off all the hard to classic rock, and overdriven blues very nicely.

12AU7 [20 GAIN]

The 12AU7 is our go-to jazz and country tube. This one has the most headroom, so it will get the loudest without breaking up. It's worth noting that the VF18 amp cannot reach gigging volume and stay clean with the other tubes. So, if you're a jazz player playing out, you'll pretty much need this tube. If you push this tube really hard, it will still break up a little, also making it good for honky tonk.

METAL

ROCK

BLUES

JAZZ

COUNTRY

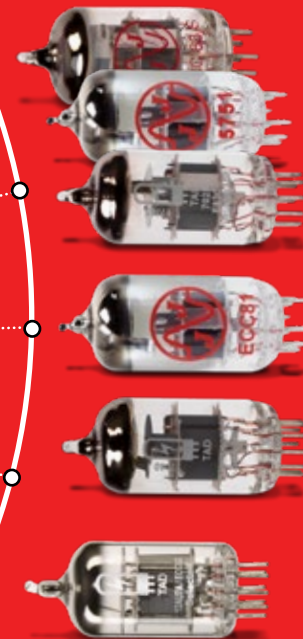

12AX7

7025

5751

12AT7

12AY7

12AU7

How often should I change my tubes

Tubes start to gradually fail due to the prolonged heat from the filaments that eventually lead to fewer electrons emitted off the cathode, a loss in vacuum seal, or a short between the elements that makes them less able to reflect the original signal.

As tubes start to go, you might notice your attack start to disappear, hissing, dips and jumps in volume, or a general staleness in the tone.

On average, preamp tubes can last up to 10,000 hours, while power tubes may need to be replaced after 1,000 to 2,000 hours of use. Rectifier tubes generally last between 5,000 and 10,000 hours.

These ballpark numbers can significantly vary depending on how your power tubes are biased, and how hard you push your amplifier when it is being used.

Whether you're a guitarist with an ear for an exact tone who plays every other night, or a player who only uses his/her tube amp from time to time, a good rule of thumb is to always have some back-up tubes on hand.

Diagnosing bad tubes

Preamp tubes

Preamp tubes last much longer than power tubes. That said, with time and use, they will eventually start wearing out. Preamp tubes usually cause problems through noise or microphonics. You might hear hissing or popping, like the sound of someone frying an egg. If you hear squeal, hum, or feedback, it's a good sign the tube is microphonic. Noise from microphonic tubes will typically increase with an increase in volume.

Power tubes

Your power tubes will be matched so that they are both drawing the same current and one tube is working equally as hard as the other. When these tubes start to give out, you will hear noise or little to no output. You can also visually identify a bad power tube if it is defective and drawing too much current. This will cause the tube to work too hard and you will see the plate components inside the glass case start to glow red. This is called red plating and is an immediate sign that tube is bad.



The "Getter," the grey/silver/black coating found on the top, side or both of tube, has changed to a ghostly white.

The filament won't glow.

A purple glow around wires or other elements can indicate vacuum leakage.

Cracked glass or loose parts inside tube

Tube Hum

Hum in an amplifier is typically due to poor lead dressing, or an issue with a ground connection. That said, tube hum can also come from a dirty or defective tube.

Tapping preamp tubes with a chopstick will create some sound that you'll hear through your speaker, but if you're hearing substantial noise or ringing, that's a good sign the tube is microphonic and needs to be replaced.

Power tubes should not make any noise when tapped. If you hear a crunching or whistling sound when tapped, you may have found the problem. If you think you have found a problematic tube, but are not sure, we recommend replacing it to confirm.

Staying on top of your tubes and making sure they are working optimally is a good way to increase the lifespan of your amp and keep it sounding great.



Looking to replace your amp tubes? StewMac has an inventory worth investigating.



SCAN ME

Gain

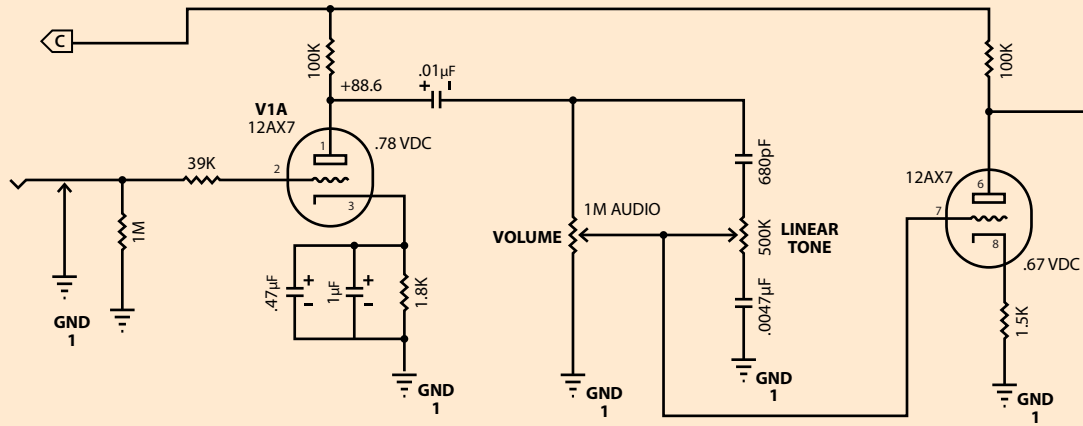

Output

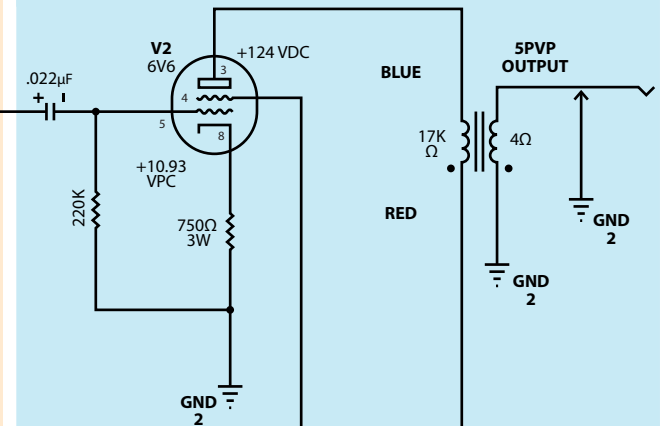

Power

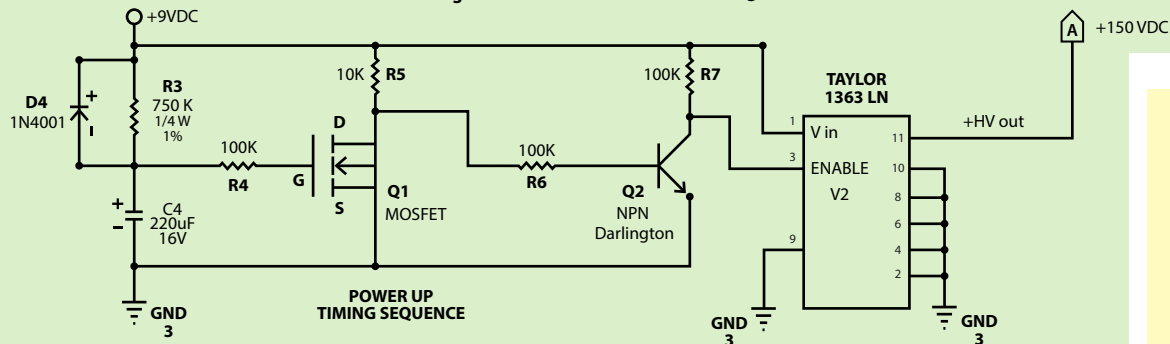
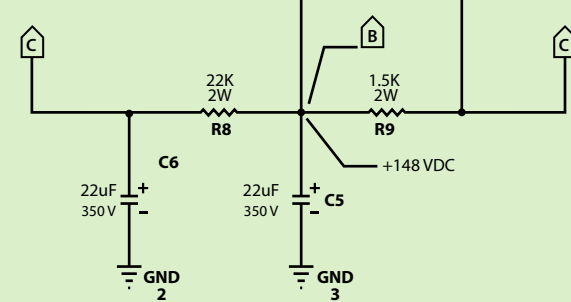
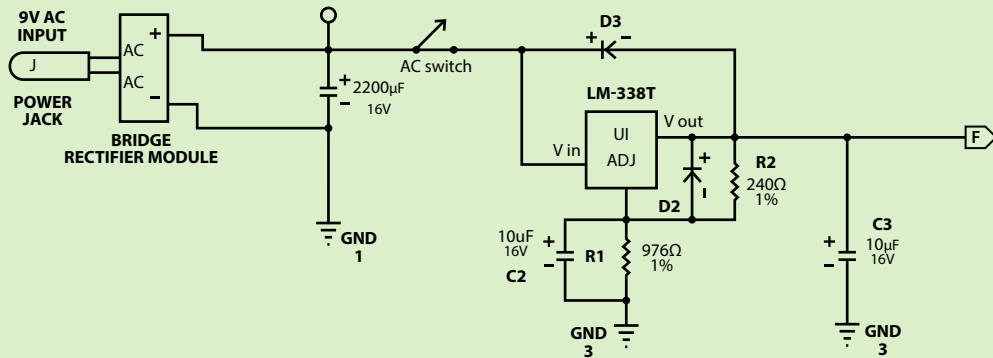

Heaters

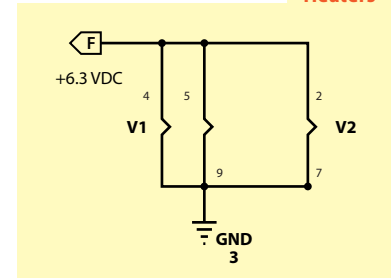

StewMac®

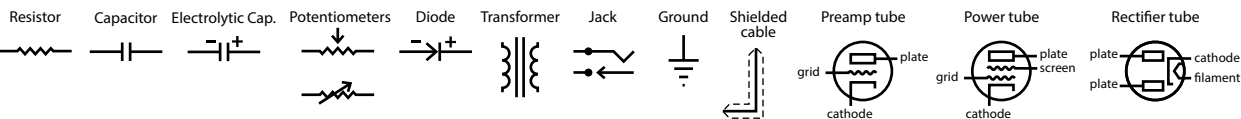

VALVE FACTORY 1
1W AMPLIFIER KIT
SCHEMATIC



**WHEN THE STEWMAC TEAM WAS
WRESTLING WITH WHAT TO CALL
THIS AMP,**

we kept thinking that the exposed tubes and components made it and its big brother, the Valve Factory 18, look like a tiny factory. Hence, the Valve Factory name was born. We hope you found building the Valve Factory 1 challenging, rewarding and inspiring, just like the music we know you'll produce with it. Now that you have the tools and the knowledge to build like a pro, what's your next StewMac kit going to be? The powerful and custom tone creating Valve Factory 18? A few pedals? Maybe even a guitar! If you need any help deciding, don't hesitate to contact us. Rock on!

YOUR FRIENDS AT STEWMAC



21 N.Shafer St., Athens, OH 45701
800-848-2273 • stewmac.com

©2025 StewMac. All rights reserved.
#10760 Updated November, 2025