

StewMac®

# Fiddle Kit Assembly Instructions

---





## Fiddle Kit Instructions

---

Welcome to the world of fiddle building! The fiddle you're about to build has a quality spruce top with curly maple sides and back. This kit is designed for the beginner and intermediate builder, with enough of the difficult work already done to give you a great head start. The fine hand work is left to you, with the help of these instructions.

Please read these instructions before starting on your fiddle, so you'll understand the process and how the parts fit. It's

important for you to "dry run" the fitting, gluing, clamping and finishing operations before trying them for real.

You'll need a flat work surface, approximately 2' x 4' or big enough for your fiddle.

**Be safe when using tools, glues, and finishes. Wear eye protection and gloves when needed, and always use proper ventilation.**

## Table of contents

---

Kit parts list .....	2	More finish coats .....	10
Recommended tools and supplies .....	2	Level sanding .....	11
Install the purflings .....	3	Attach the fingerboard .....	11
Prepare the neck .....	4	Final-finish the neck .....	12
Fit the neck .....	5	Re-install the tailgut saddle .....	12
Cut the mortise .....	7	Fitting the tuning pegs .....	12
Glue the neck .....	7	Slot the nut .....	13
Install the tailgut saddle .....	8	Install the soundpost .....	13
Install the endpin .....	9	Fit the bridge .....	14
Wood and finish preparation .....	9	Install the tailgut .....	15
Applying varnish .....	9	Install the fine tuner .....	15
Apply the first two finish coats .....	10	Install the chinrest .....	16
Coloring the varnish .....	10	String the fiddle .....	16

## Kit parts list

Please make sure you have all these parts before assembling your kit. It's important to completely rehearse all fitting and clamping operations before applying glue or finishing materials.

- 1 Carved maple neck, tuning pegs, fingerboard and nut
- 2 Carved maple top, back and side assembly
- 3 Chinrest mounting bracket
- 4 Cork
- 5 Purfling
- 6 Fine tuner
- 7 Tailpiece and tailgut
- 8 Chinrest
- 9 Tailgut saddle
- 10 Maple bridge
- 11 Soundpost blank
- 12 Endpin

Not pictured: rubber binding band

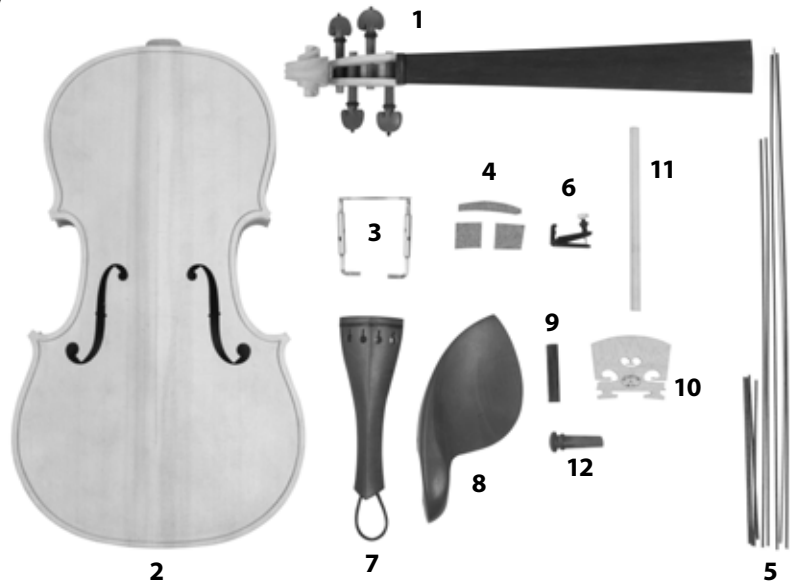

## Recommended tools, supplies and reference materials

The following tools and supplies are recommended to assemble your kit. Most of these tools are standard woodworking items, though a few specialty tools are also shown. Where applicable, item numbers for ordering from Stewart-MacDonald are included.

### Tools

Steel rule with millimeters (#4894), or at least 1/64" scale  
Chisels: micro chisels (#1628), brace chisel (#1629)  
X-acto knife, several blades  
Clamps: Cam Clamp (#3724), Swivel Handle Clamp (#3704)  
Drill with 1/16" and 1/8" (or 1.5mm) drill bit  
Feeler gauge (#1811)  
Scraper blade with curved end (#0628)  
Files: miscellaneous sizes; round, flat, and curved shapes  
nut slotting files .010", .020", .032" (#0821, 0828, 0831)  
Razor saw (#3598)  
Tapered violin reamer (#0344)  
Soundpost gauge (#0389)  
Soundpost setter (#0388)

### Supplies

Pencil  
Binding tape (#0677)  
Titebond wood glue (#0620)  
3M Gold Fre-Cut® Sandpaper 150, 220, 320, 400, 800-grit  
Micro Finishing Paper 1500-grit  
(#5562 Sandpaper/Finishing Sampler Package)  
Quality paint brush  
Lint-free cloth and cotton  
General Finishes Enduro-Var Varnish (#1785)  
ColorTone Concentrated Liquid Stains (optional)  
vMedium Brown (#5033), Vintage Amber (#5030)  
Tung oil (#0624)  
Case  
Violin bow, cherrywood (#4275)

### Reference

Violin Setup DVD (#5622)

## Install the purflings

The top and back are routed for body purflings, but you will need to complete the “points” of the channels, connect the channels at the neck end, and clean out any burrs left during manufacture. Use an X-acto knife and small micro-chisel to cut the points, clean up the corners, shape the channel and clean the bottom (**top photo**). The tang of a small file can be ground so that it’s sharp on all edges — creating a handy micro-chisel. You can also smooth rough spots on the channel walls by using a small thin blade with sandpaper stuck to it.

On the back of the fiddle, there’s a gap in the purfling channel near the neck joint. This blank area gives you the option of creating a decorative purfling design, which some builders prefer. In these instructions, we’ll simply connect the ends of the channel at this point.

Create a template by drawing a 6" radius (152.4mm radius) onto stiff cardboard or plastic, and lay it on the back to trace a curved line connecting the channel ends (**middle photos**). Using your template as a guide, cut lightly with a sharp knife. Slowly make your cuts deeper until you can chisel out the wood with your small micro-chisel.

When cutting the purfling to fit, you can get sharp corner joints by cutting with an X-acto knife or a sharp chisel (**bottom photo**). To help you visualize the angle you’re cutting, here’s a tip: cut the corner points with a sharp chisel whose flat side has been polished to a mirror shine. As you hold the chisel on the purfling, it will reflect itself in the chisel to show you how the joint will look. By cutting carefully, the laminations of the purfling will meet evenly at the miter joints without a gap.

Be careful when bending the purfling: overbending will cause it to crack or break. To keep the purfling from breaking while fitting it to the channels, use a rag dipped in warm water and wipe the purfling in the areas where you need to make a tight bend. Don’t immerse the purfling in water — it will delaminate! Too much water will cause purfling to swell bigger than the channel.

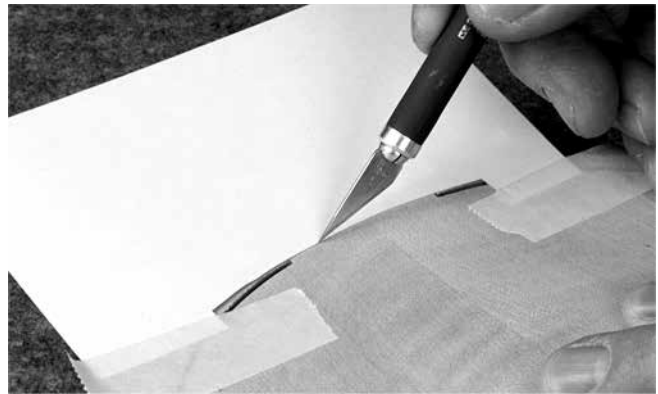
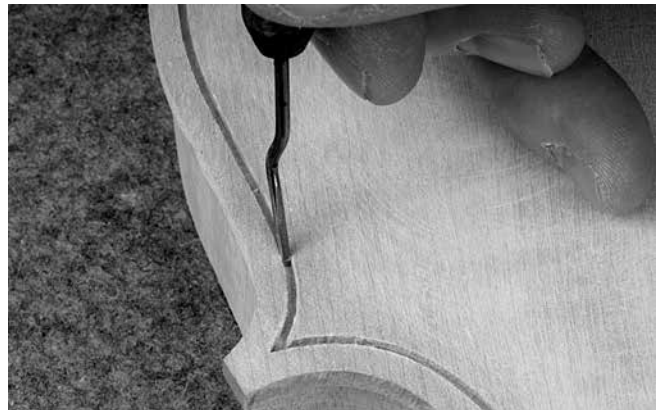



For the tight curves, create your own bending iron using a piece of copper plumbing pipe and a propane torch (**above photo**). Heat the pipe, keeping the temperature low, and bend the damp purfling against the copper.

The dampened purfling is left to dry in its curved shape. While one joint is drying, you can work on another area (photo right). Remove the dry-fit purflings, handling them gently. Glue the pieces in place with Titebond glue. (Tradi-

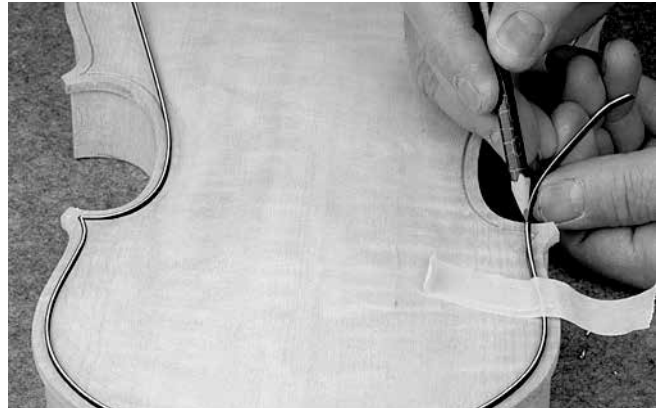

tional violin makers use heated Hide Glue, but it's difficult to use because it cools and sets very quickly. For these instructions we use Titebond, a better choice for first-time builders.)

When the glue has dried, trim and scrape the purfling to lower its height so that it's flush with the top and back surfaces. Don't overwork it at this stage. You'll final-sand and smooth these purflings later, after the top is glued on.

## Prepare the neck

For this step, the fingerboard and nut need to be temporarily "spot-glued" to the neck, with just a drop or two of glue to hold them in position. Your kit may have arrived with the fingerboard and nut already spot-glued; if they're loose, use a drop or two of glue to temporarily join them to the neck for this step. The wall of the pegbox aligns with the nut.

After fitting the neck to the body, the fingerboard will be removed for finishing, then permanently installed after the instrument is finished.

Before fitting the neck to the body, shape the neck, including its heel and scroll (**photos**). Good tools for this work include chisels, files (both round and flat), sandpaper, and scrapers. A good tool for tight areas is sandpaper wrapped around dowels. Small strips of sandpaper make great scroll sanders.

The fingerboard edges are already good straight lines, so shape the neck to match these edges where the two meet. However, the fingerboard may need to be shaped to fit the neck if it is wider and its edges overhang. Smooth the neck/fingerboard so their edges are flush.

Round the fingerboard edges for comfort.

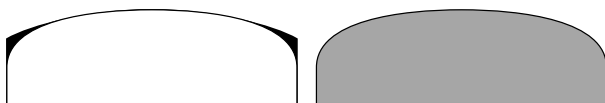

## Fit the neck

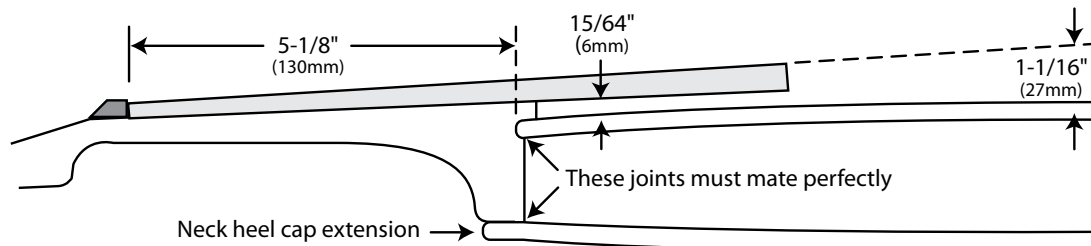

In fitting the neck to the body, the measurements shown in the **diagram** are critical. Double-check these points:

- The centerline of the neck and fingerboard must align with the body's centerline.
- The angle of the neck's fingerboard gluing surface parallels the plane of the top.
- At the neck joint, the height of the fingerboard over the body is  $15/64$ " (6mm).
- A straightedge laid on top of the fingerboard, and extending over the top of the instrument, should measure  $1-1/16$ " (27mm) above the top at the bridge location.
- The bottom of the heel and the back of the neck must mate perfectly with the neck mortise and neck heel cap extension of the back.
- The nut/fingerboard joint is  $5-1/8$ " (130mm) from the front edge of the top.

Put white pencil marks on each narrow side of the fingerboard at  $5-1/8$ " (130mm) from where the nut joins the fingerboard. These marks will be used later as a reference point when fitting the neck to the body.

A simple tool for fitting the neck is a Violin Neck Angle Gauge which makes it easy to see when the neck is at the proper angle and height above the top (**photos**). Make one out of scrap wood:

The neck-set stick is  $13-1/4$ " x  $3/4$ " (337mm x 19mm), with one very straight edge placed along the center of the fingerboard. Butted against the nut, the stick reaches over the bridge area. A smaller stick,  $1-1/16$ " (27mm) long, is glued to the main stick at an angle so its end is square to the top. This end rests squarely on the top at the bridge position. A small clamp will press the neck downward toward the body.

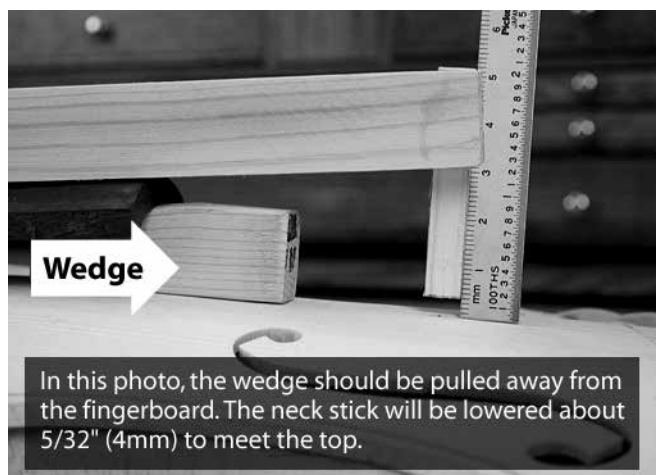
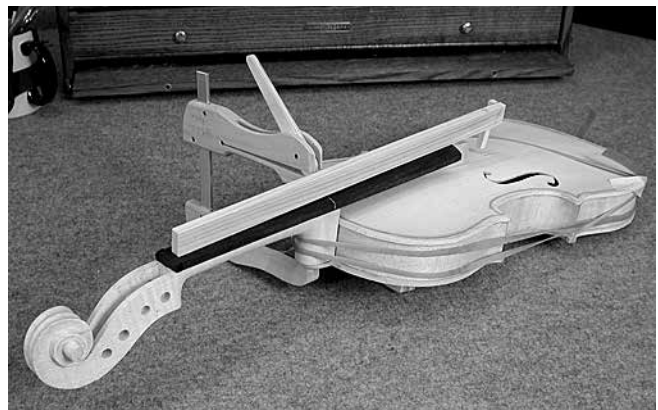

Insert the endpin temporarily, and tie a rubber band to it. Wrap the rubber band around the fiddle rims a couple of times from end to end, and tie it off. Stretch out the rubber band and set the neck in place. The rubber will clamp the neck against the body. This way, it's easy to take the neck in and out during fitting. Clamp the neck down into the neck joint using a small clamp that won't get in the way of

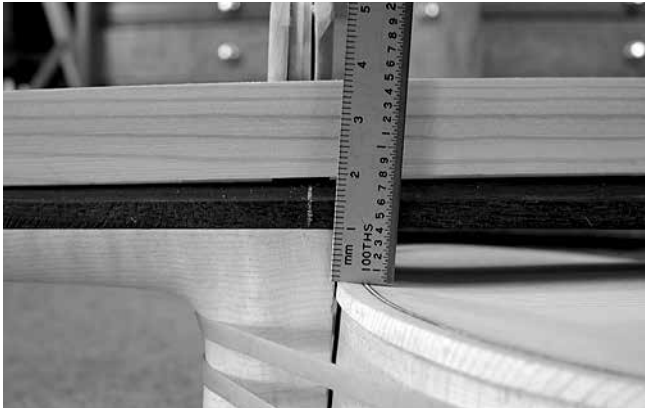

the neck-set stick (which must remain on center). A wedge of wood placed under the fingerboard will allow you to change the neck angle. Slide the wedge in or out to tip the neck if needed.

The neck **pictured above** needs to be lowered by about  $5/32$ " (4mm) at the heel and also at the bridge position. This means we're dropping the neck down onto the body.

With the rubber bands holding the neck in place, align the neck so that it centers on the top's centerline. A feeler gauge placed under the bass or treble side of the neck heel may be handy for making fine adjustments in the neck angle (**photo below**). The neck needs to be very accurately aligned for the next step.



At this point, the neck is nicely aligned, but its heel isn't flush against the sides it will be glued to (it's resting against the overhanging edges of the top and back). The next step is to draw a line on the heel of the neck that is parallel to the sides of the fiddle. Place a small block of wood or Plexiglas (about  $3/16$ " (4.8mm) thick) on the fiddle next to the neck heel and use it as a straightedge to trace a pencil line onto the neck (**photo top right**). This line records the angle that you'll follow when you trim the end of the neck heel to match



the fiddle body. (This is not the line you will cut on — it is only recording the proper angle.)

Next, draw a line indicating how much wood to take off the bottom of the heel where it will meet the heel cap. Keep in mind that indicates a  $15/64$ " (6mm) gap between the fingerboard and the top (see **diagram**, previous page). You want to reduce enough wood from the heel to lower the fingerboard to this height ( $5/32$ " (4mm) in the case of the fiddle in these photos).

Before unclamping, trace along both sides of the heel with pencil to draw the shape of the heel onto the fiddle body. This marks the area where you will cut a mortise, or pocket, for inseting the heel into the body.

Remove the neck and mark the wood to be cut away from the heel. The white marks you made on the fingerboard indicate where the heel will be flush with the sides. You will be inseting approximately  $3/16$ " of wood (about 5mm) into the mortise you make in the body, so leave that much wood for the neck joint. Staying parallel to the angle line you traced onto the heel, mark the wood to be cut away from the heel. Also mark the wood to be cut away from the base of the heel, where it meets the end cap ( $5/32$ " (4mm) in our case).

In the **photo below**, the pencil-darkened area marks the wood to be cut away. Remove the wood from the heel with a thin saw or with chisels and files. (Removing the fingerboard at this stage makes the cutting easier.)

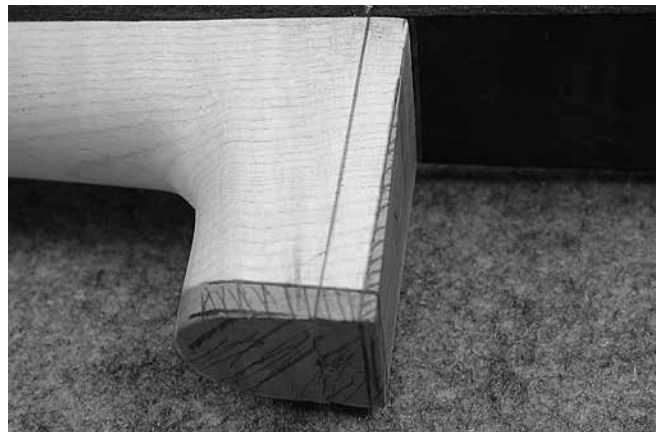



## Cut the mortise

The heel of the neck will be glued into a mortise cut into the body. Cut this mortise following the marks you made by tracing the shape of the neck heel onto the body. Cut inside the lines; it's easy to enlarge the mortise, but you don't want it to be oversized.

The depth of the neck mortise is approximately 3/16" (5mm). The depth is less critical than the shape: you need a good, snug fit, and the surfaces should be flat and smooth, to match the shape of the neck heel.

A small razor saw is good for starting the cuts and deepening the walls of the mortise, followed by sharp chisels. Stay inside your pencil lines while cutting, and carefully increase the size until the neck fit is perfect.

As you create the mortise, keep your chisels sharp and keep the mortise shape flat and smooth. This is tricky cutting, but take your time and remove only a little bit with each cut. Slow and careful will give you great results. The neck joint must be snug, but not too tight. If it's too tight it will put undue stress on the surrounding wood when clamped for gluing, and that could split the wood holding the neck.

Refer to your pencil line marking the angle of the neck set. Keep this line parallel to the sides of the fiddle. If it's not parallel, remove tiny amounts of wood to adjust the angle of the neck. Check your progress often.

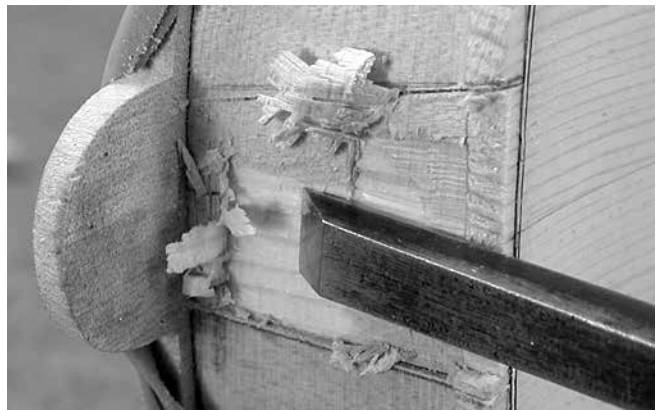

## Glue the neck

When the neck fit is correct, you are ready to glue the neck in place (you may wish to spot-glue the fingerboard back on in order to test the centerline alignment again). As always, dry-clamp the glue joint to perfect your clamping methods before actually using glue. Make sure you have enough time to fit everything together and apply clamping pressure (especially important with hide glue, which sets quickly). A well-rehearsed clamping procedure will give you accurate results.

The neck can be clamped with a single C-clamp contacting the heel cap and the top of the fingerboard. In the **photos below** we've made a clamping caul that allows the neck-set

stick to stay on during the clamping. This isn't necessary, but it's a good way to keep an eye on maintaining the neck angle during this procedure.

To make this caul, cut two pieces of wood that will stand slightly taller than the neck-set stick. Shape them to match the curve of the fingerboard, and glue them onto the sides of the stick. A bridge of wood across the tops of these two pieces will give you a clamping surface that allows the neck-set stick to stay on during gluing. While gluing, you can check the neck angle with the neck-set stick's 1-1/16" (27mm) finger.

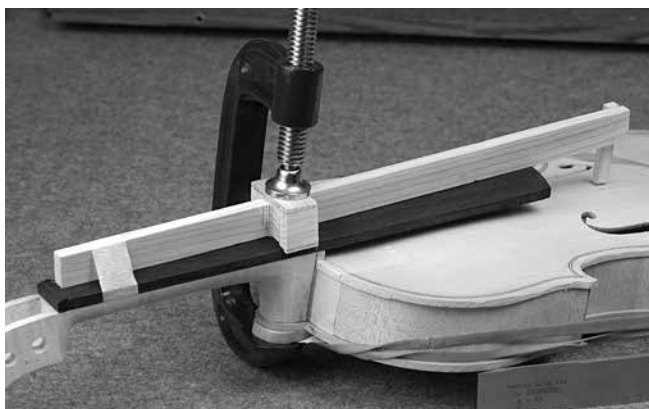

## Install the tailgut saddle

The tailgut saddle supports the plastic tailpiece fastener and keeps it from damaging the softer wood of the fiddle's top. Professional makers don't cut and fit the saddle until the fiddle is finished and buffed, but we recommend that you do it now. After finishing the fiddle, you'll glue the saddle into the notch you create now.

To install the tailgut saddle you'll need to cut a small notch into the top above the endpin hole. This notch should be  $\frac{3}{16}$ " (5mm) wide,  $1\text{-}\frac{3}{8}$ " (35mm) long, and  $\frac{1}{8}$ " (3mm) deep.

The saddle is  $1\text{-}\frac{3}{8}$ " (35mm) long x  $\frac{5}{16}$ " (8mm) high and needs to be shaped so that a ridge rises along the center of one side. This ridge is  $\frac{3}{4}$ " (19mm) wide, and will stand  $\frac{3}{16}$ " (5mm) above the fiddle's spruce top.

Square-up the saddle blank on a flat surface covered with 100-grit sandpaper. Make sure the bottom and one side are square to each other — these are your gluing surfaces, and this is the side which will have the ridge described above. Cut and square the sides of the saddle to match the dimensions of the diagram. Mark "Top" on the top edge to keep track of which end is up while you're working.

Use a small file, a chisel or plane, and sandpaper to shape the saddle blank, keeping your squared edges clean and ready for gluing.

When the saddle blank is the right size, hold it firmly on center above the endpin hole and on each side make a clean, sharp cut in the spruce top using an X-acto knife (**top photos**). Deepen these cuts with the knife, and then use the knife and chisels to cut the mortise — the notch that the saddle will glue into after finishing.

Compare the saddle to the mortise often as you work. When

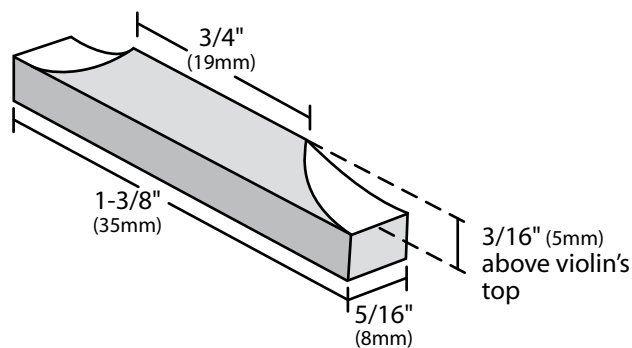

the fit is good, hold the saddle blank in place and mark around it with a pencil to show where the top surface meets it. Using this mark and the dimensions in the **diagram above** as a guide, shape the saddle.

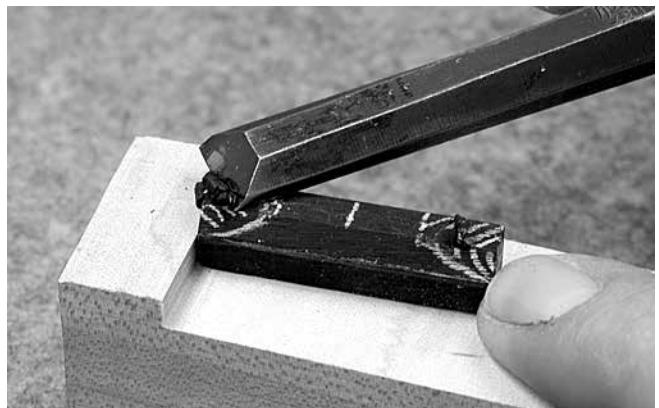
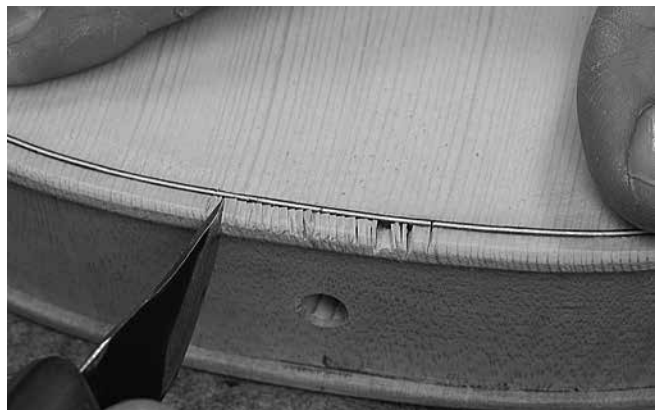

To hold the saddle for carving, use a scrap of wood with a raised stop on one end that you can butt the saddle against. This will keep your fingers safely away from the cutting tools.

Once the saddle is shaped and fits the notch well, set it aside. It will be glued in after finishing the violin.

## Install the endpin

---

The endpin mounting hole is pre-drilled, but will need to be reamed to accept the endpin. It won't take much to shape the hole to fit the peg; you can do this with a bit of sandpaper wrapped around the tip of the peg itself (a violin reamer

makes this easy). Don't ream much! Test often! When the endpin fits, remove it until after the finish has been applied.

Now you're ready for finishing!

## Wood and finish preparation

---

Many makers remove the fingerboard and spot-glue on a temporary "dummy" board that stops at the end of the neck heel (tape can be used to mask it off). This protects the neck's gluing surface during finishing, and the absence of the fingerboard's overhang makes finishing the top easy.

The fiddle is now "in the white" and ready for careful wood preparation before finishing. Prepping a fiddle is enjoyable, and involves scraping, filing, sanding, and more scraping. Final-scraping leaves a smooth surface without the scratches of sandpaper, and it exposes the wood grain nicely for finishing. Scraping takes some practice, and your scraper must be sharp.

Shape the overhang of the top and back using a file, knife, scraper, and sandpaper (**photo**). Use these same tools to remove all scratches from the sides, top, and back. After thoroughly prepping the surfaces, dampen the wood with a rag dipped in hot water and well squeezed-out to raise the grain (dampen the wood, don't wet it).



When the wood is dry, scrape or sand it again, smoothing away the fibers that are raised by dampening the wood.

Mask off the notch you cut for the tailgut saddle, to keep it free of finish (for a good glue joint later).

## Applying varnish

---

We recommend General Finishes Enduro-Var Waterbase Brushing Urethane Varnish, a traditional finish that can be sprayed, brushed, or rubbed onto the instrument. Enduro-Var is a good choice for a first-time fiddle builder; it's easy to apply, builds quickly, and dries to a hard luster. It has a slight amber tint that is typical for fiddles.

It's important to clean and dust your finishing room before applying varnish. This is to avoid raising dust that can settle on the surface while the varnish is curing.

You can also stain the wood or tint the varnish to achieve a specific color or shade using ColorTone concentrated liquid stains.

Apply the varnish with a "tampon" made of a lint-free cloth wrapped tightly around a cotton ball. Rub the varnish into the wood using circular, figure-eight motions. Watch for wet areas, and wipe them up with the tampon. Never stop moving with the varnish-wet rag, or it will stick. You will end up using very little finish, and the wood will be well sealed. Even with no color added, the varnish brings out a great color in the wood.

After your sealer coat is dry, use a light touch to remove any lint or dust with 400-grit sandpaper (we prefer 3M Gold Fre-Cut® Sandpaper). Don't actually sand the wood — just kiss the surface, leaving your sealer coat intact.

Apply the first coat of varnish using a quality brush. On the fiddle top, brush only lengthwise along grain lines of the spruce. The maple back can be brushed both crosswise and lengthwise. Enduro-Var has a slight amber hue, so each coat adds more richness and color.

Clean your brushes well after every use, and hang them in a glass jar with a bit of water in it. Keep a dust-proof cover on the jars, and suspend the brushes by their handles so the bristles don't touch the bottom.

If you have professional spray equipment, you can spray the coats of varnish. With spraying, it's easier to achieve an even coverage than with brushing. You can also spray coloring stain on the instrument in the first coats, without the blotchy look of hand-staining unfinished wood.

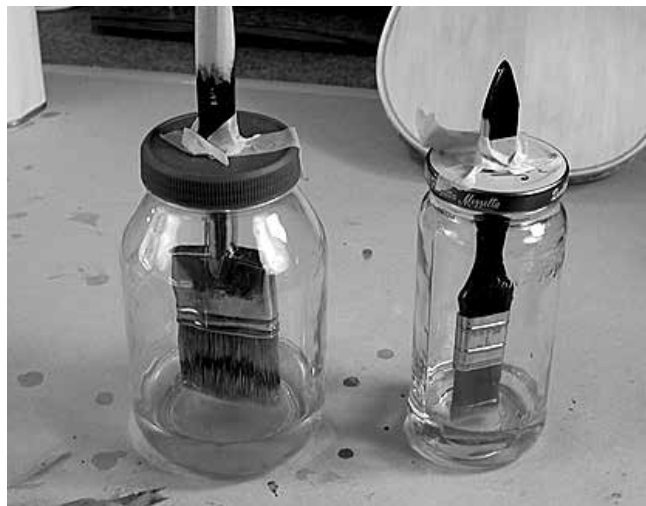

## Apply the first two finish coats

---

Apply two coats of varnish, one coat a day, and let the last coat dry for at least two days. After it's thoroughly dry, lightly sand the instrument with 220-grit or 320-grit gold sandpaper to remove ONLY high spots in the finish (don't sand through the thinner parts of the finish).

The next step will be to apply two more coats of varnish, but here is where you need to decide whether you're using

colored or uncolored varnish. Unfinished varnish gives a rich honey amber color. We've decided to tint our varnish to get a richer, reddish color.

If you're coloring the varnish, follow the steps in the next section. If you're using uncolored varnish, skip the Coloring step and resume with "More finish coats" below.

## Coloring the varnish

---

Applying color to bare wood is tricky and it streaks easily, but now that you have two coats of varnish applied, you can add color to the next two coats and it's easier to get good results. In this step, you'll add color to your varnish and rub it onto the existing finish. You'll find that you can highlight areas and create a subtle sunburst effect near the edges of the fiddle.

For transparent color, use ColorTone stains added to a little unthinned varnish. We used a mix of medium brown and vintage amber. Pour the colored varnish into a flat bowl and dip your finish tampon lightly into it to pick up color. Work the colored varnish into the finish where you choose, building the color toward the edges to create a subtle sunburst effect. Use a small brush to apply color to the surfaces of the scroll.

## More finish coats

---

Brush two more coats of varnish, one coat per day. Brush in long straight strokes that slightly overlap. Begin and end your brush stroke off the instrument, like an airplane gliding onto the surface. Don't stop a stroke in the middle of the instrument — continue moving off the edge. Use a light touch: brushing over color can lift the color and cause streaks.

If you have professional spray equipment, you can spray the coats of varnish.

At this point, you've applied four coats of varnish (you may or may not have added color between coats 2 and 3). Give the finish time to cure, 2 days or more. If the varnish imprints easily with a thumbprint, it is not dry enough to sand or spray.

## Level-sanding

When the last coat of varnish applied is dry, carefully level it with 320- and/or 400-grit sandpaper. The high parts of the finish will be flattened by the sanding, and become dull. That leaves the low areas which are still shiny (shown in the **photo**). Sand until you start removing some of these low spots, but not all of them. They will be filled in with the next finish coats.

After sanding, apply a coat of varnish and let it dry overnight. If the finish has cured perfectly level and smooth, with the sheen you're looking for, you're done finishing. It's more likely that the varnish will have filled in most of the low spots, but not all.

If it has a smooth surface with only a few low spots, you're probably done applying varnish. You won't know until you try sanding the coat smooth. Start with 800-grit Fre-Cut paper and graduate to 1200-grit Micro-Finishing paper. If you still have some low spots in the finish, and are unsure whether they would disappear when buffing the finish, it's a good idea to add another coat of varnish.

Set the fiddle aside to cure for one to three weeks before fitting the parts.

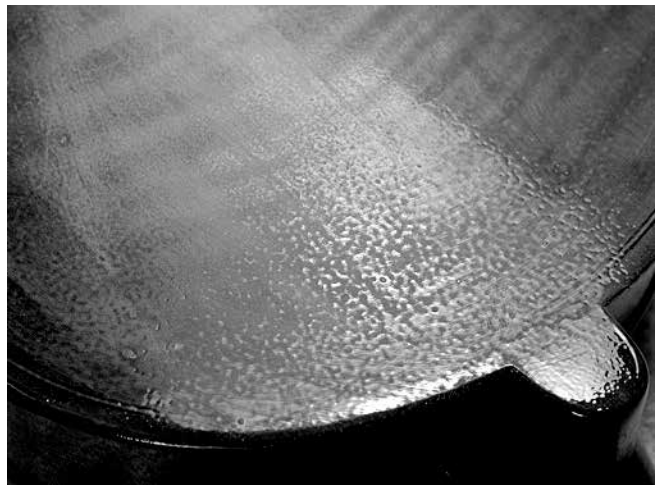

After the varnish has cured, sand the finish to a satin sheen with 1200-grit, or polish it to a high gloss, whichever you prefer. Use a power buffer if you own one, but be careful: a buffing wheel can easily heat the varnish and "pull" or streak it. Hand-buffing with medium and fine grit polishing compounds is safer.

## Attach the fingerboard

Use a sharp knife to remove the tape or dummy fingerboard from the neck. Clean the glue remnants from the surface of the neck and fingerboard before gluing the fingerboard to the neck.

Align the fingerboard carefully, keeping in mind the 5-1/8" (130mm) measurement from the edge of the nut to the edge of the fiddle top (see **diagram** page 5). Do a dry-run of your clamping procedure to be sure of your positioning, then apply the glue and clamp.

Spread the glue in a thin layer to avoid excess squeeze-out, and wrap the fingerboard to the neck using the rubber band provided. Rubber band clamping gives you a chance to clean away glue squeeze-out, and move the fingerboard to align it during the first few wraps of the band. Once you've wrapped the neck from end to end, you'll have a very strong clamp holding the fingerboard in place. Let it dry overnight.

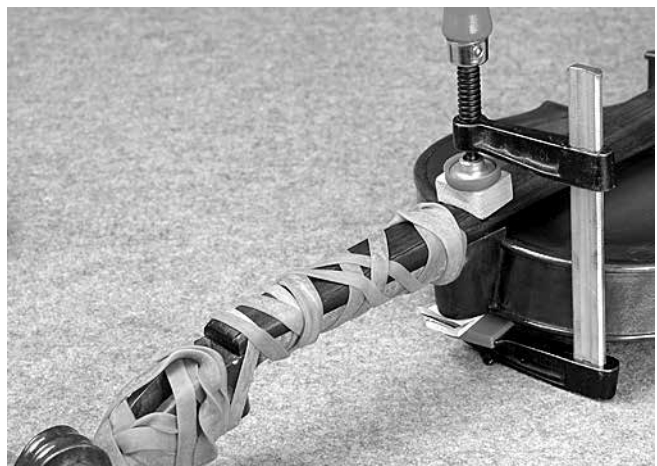

## Final-finish the neck

Traditionally, the color of the fiddle covers the peghead and heel of the neck, but feathers away to an almost-bare playing surface on the back of the neck. By sanding and scraping, feather the finish at the heel and peghead creating a quick, smooth transition blend from the finish to bare wood.

Scrape and sand the maple smooth, then add a light stain for a traditional look. Practice on a scrap piece of maple



to find the color you want. We used ColorTone Amber and Medium Brown, in tiny amounts, added to Behkol solvent until we got the look we liked.

Then we stained the real thing. Allow the stain to dry, then rub the neck with a clean rag to burnish it. Wipe on a coat or two of Tung Oil for a final finish that has a bare wood feel.



## Re-install the tailgut saddle

Remove the mask from the mortise you cut for the saddle. A little careful cleanup will probably be needed. Glue the saddle in place. If you chose to cut and fit the saddle after

finishing, now is the time for that step (see "Install the tailgut saddle").

## Fit the tuning pegs

The pegholes are tapered to accept the tuning pegs, but you'll need to refine this shape with a violin peg reamer for a good fit. A few careful turns should be all that's needed. Check the fit after every twist of the reamer. The **diagram** shows that the band around the tapered shaft is generally 1/2" (12 to 14 mm) from the side of the pegbox. Try to make all four pegs extend the same distance.

When each peg is properly seated and operating smoothly, mark the ends of the pegs with a pencil to show where the excess wood needs to be cut away. Remove the pegs and trim them to length, then smooth the cut ends with sandpaper.

Put the trimmed pegs back in their respective holes, and mark the location of the string hole in each peg. The string hole should be slightly off-center (as measured within the pegbox), toward the knob side of each peg. Use an awl to make a start for the hole to be drilled.

Carefully drill a 1/16" (1.5mm) hole through each peg, then smooth the sharp edges of the hole, for less stress on the string. When drilling, hold the peg down firmly on a hard wood surface so that when the drill bit comes through the other side it doesn't "blow-out" wood.

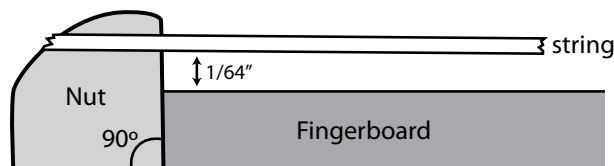
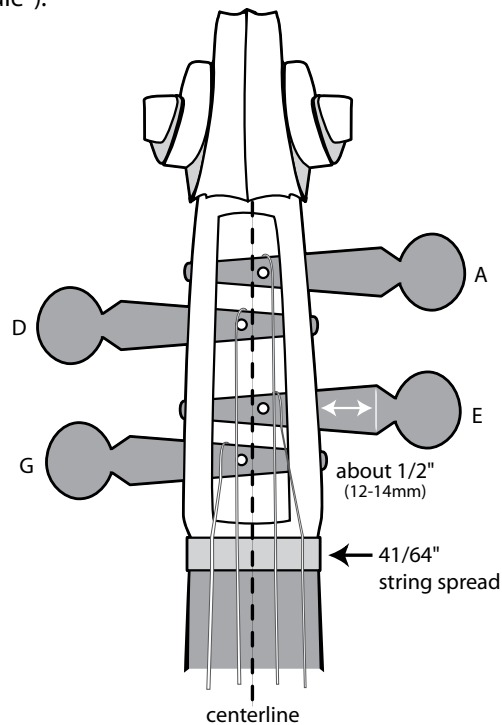

## Slot the nut

The nut blank comes roughly shaped to the correct size. Be sure the bottom is flat, as well as the front wall that glues to the fingerboard. If necessary, square it up on your flat sanding board.

String spacing at the nut should be  $41/64$ " (16.3mm) between the two outside strings. With the two inner slots added, the space between string slots should be  $7/32$ " (5.43mm).

The bottom of each string slot should be  $1/64$ " (0.3mm)

above the fingerboard (slightly less than the thickness of a business card). The depth of the slot should be about  $1/3$  of the string's diameter. Use a triangular file to start the slots, and finish them with small round files that match the string diameters. Nut slotting files work well for this.

File the nut to its final shape, smooth its surfaces and make sure it's not wider than the neck. You might want to remove it for this work and glue it back on afterward.

## Install the soundpost

Be very careful and precise when fitting the soundpost since it determines the overall volume and tone of the fiddle.

The soundpost is fitted inside the instrument, between the top and back. It's installed about  $1/8$ " (3mm) behind the bridge's treble foot (see **diagram**) with its grain or annual rings perpendicular to that of the top and back. Don't use glue to secure the soundpost. The fit should be snug, but doesn't need to be tight, since pressure from the strings will provide additional clamping force.

Carefully cut the soundpost to roughly the proper length (described below). It may take several attempts to get it right, so consider making one or two practice posts from scrap. Be patient and do not remove wood too quickly. The soundpost ends are not parallel. They must be carved to conform to the inner shapes of the body's top and back. As you get close to final size, dampen the end of the soundpost — this will raise the grain and allow you to trim off a very thin shaving of wood as you approach the final fit.

Two ways to rough-in the length of the soundpost:

**With a soundpost gauge:** Insert the soundpost marking gauge through the treble f-hole, and hold it in the soundpost location (**photos**). Set the gauge and transfer its measurement to the post, using a pencil to mark the approximate angle of the curve of the top and back. Trim the post to length, trimming the ends to match the angles of the surfaces they will rest against.

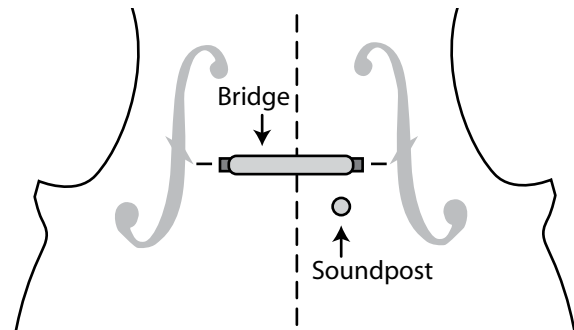

**Without a soundpost gauge:** Look through the endpin hole to see the curve of the top and back. Trim the soundpost bottom to approximate the back curve. Stand the soundpost in the F-hole. Mark the angle of the fiddle top onto the soundpost in pencil. Use this line as a guide and trim the post to length, approximating the angle of the surface the post will rest against. Try fitting the post and remove wood if necessary to get a good fit. Remove only small amounts of wood, test-fitting often.

Use a soundpost setter to position the soundpost. The sharp end of the setter is poked into the side of the soundpost and inserted through the treble side F-hole. You can sight the position of the soundpost through the endpin hole and the treble F-hole.

When the soundpost has the proper length and shape, install it in the fiddle. Moistening the ends of the post will help it stay in place.



## Fit the bridge

The bridge's taller side is for the bass strings, with the treble strings sitting slightly lower and closer to the fingerboard. The bridge will need final height adjustment and fitting.

Flatten the bridge by sanding it on a flat surface. Do this sanding on the back of the bridge. Scribble with pencil on this side, then sand until the pencil marks are gone. The disappearing marks will show whether you're sanding the whole surface evenly.

The feet of the bridge must conform to the curved top of the fiddle. Set the bridge in place and trace the curve of the top onto it using a "half pencil" (a pencil sanded flat on one side) (**above photo**). Trim the feet to this shape, leaving the pencil line showing (this leaves wood to work with in shaping the feet).

Trim the feet so that the bridge sits square to the top (**above photo**). Carving the feet accurately can be difficult. A good method is to put a small piece of 120-grit sandpaper on the top in the bridge location and sand the feet with short strokes until they match the top's curve. Be careful to keep the bridge standing up straight, perpendicular to the top.

With a pencil, mark the locations for the two outer strings (G and E) 1-5/16" (33.5mm) apart and centered. Mark the two remaining strings (D and A) at 7/16" (11.3mm) apart.

To check the height of the bridge, lay a straightedge on the fingerboard. Extend this straightedge to the bridge, and make a pencil mark showing this height at the G string position. Make another mark at the E string position (these are the two outer strings).

These two marks indicate the fingerboard line extended to the bridge. Next, make a second pair of marks above these two, indicating a higher point for shaping the top of the bridge. Raise the G string mark by 9/32" (7mm) on the bass side, and raise the E string mark by 7/32" (5.5mm) on the treble side. Draw a curve between these two marks using the **bridge template** on the inside back cover.

The E-string slot should be 3/32" (2.5 - 3mm) above the fingerboard line, and the G-string should be 11/64" (4.5mm). If only a small adjustment is required [less than 1/64" (1mm)], remove material from the feet by sanding. If more must be removed, take the material from the top rather than the feet. The feet should remain between 5/64" (1.9mm) to 1/8" (2.5mm) thick.

If the bridge is too heavy it will affect the fiddle's tone, so it will need to be thinned and shaped. It should be approxi-

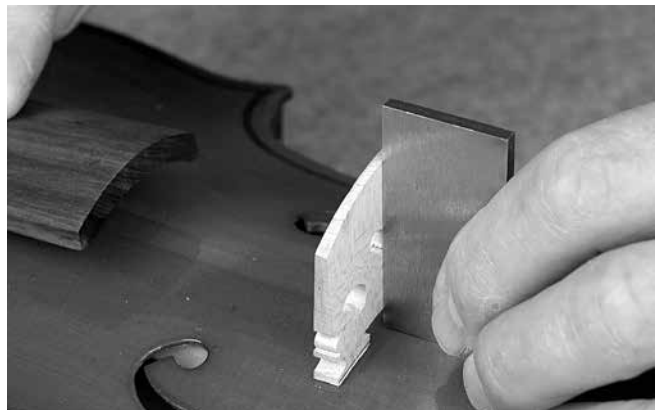
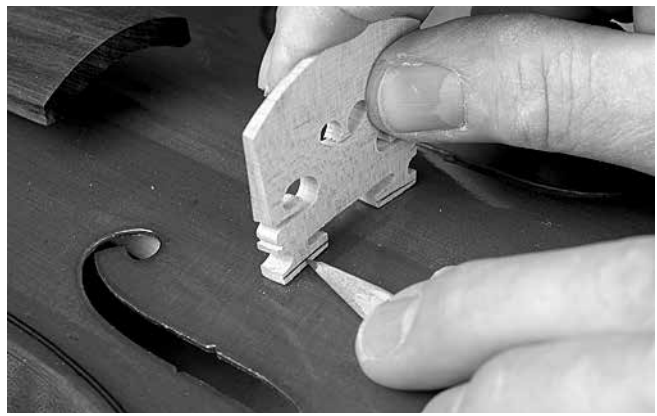

mately 3/64" (1.3mm) thick at the top and 5/32" (4mm) at the base. The back of the bridge (towards the tailpiece) should remain flat and perpendicular to the top when installed. The front side of the bridge should taper or curve inward slightly just above the feet. Sand the bridge to thickness or use a chisel, file, or knife.

In the **photo below**, the bridge has been fitted to the top, trimmed to height, and shaped round on the front. It rests squarely on its feet, and is ready to be smoothed of scratches.

The bridge can be further reduced in weight by beveling the

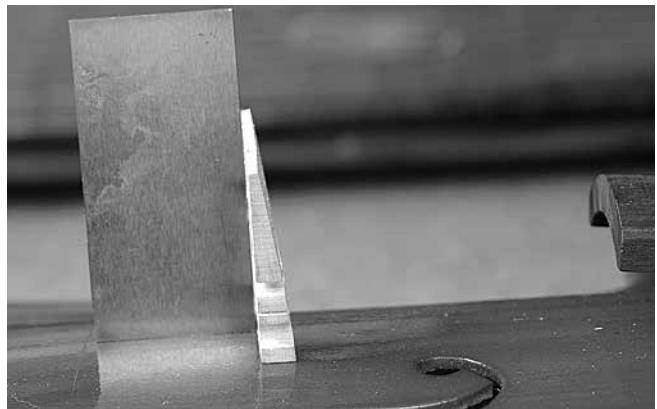



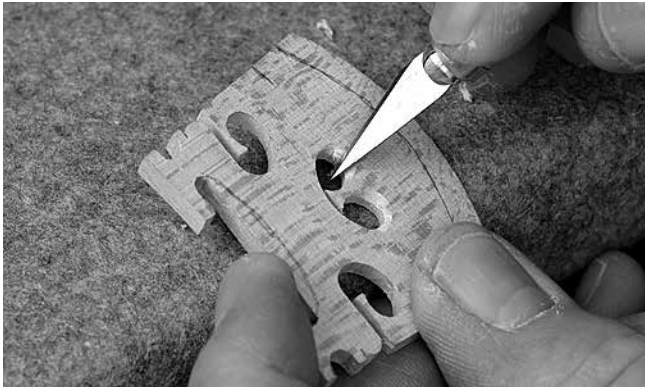

sides and the edges of the cutaway holes, and thinning the feet if they are too thick. Raising the bottom arch between the feet reduces mass, and looks good, too.

The string notches will be cut later, when the strings are on. The bridge is held in place by the string tension, and no glue is used.

Before

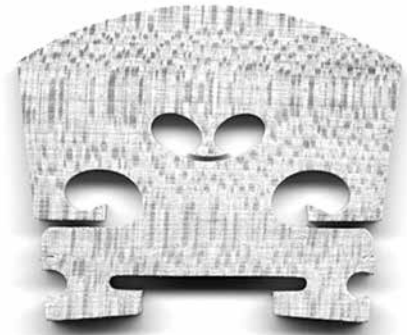

After

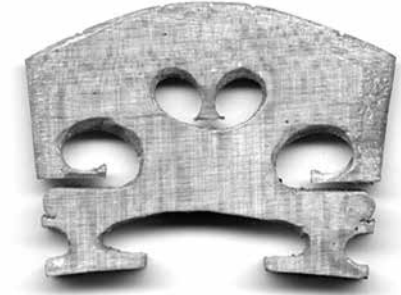

## Install the tailgut

Insert the endpin into the fiddle. Secure the tailgut to the tailpiece, installing it as in the **photo**. Remove the thumbscrews, push each threaded end through the tailpiece holes, and thread the thumbscrews back on. When attached to the instrument, the end of the tailpiece should be almost touching the front edge of the tailgut saddle. Adjust the tailgut's length, using the thumbscrews, to locate the tailpiece at that point. Trim excess material from the tailgut, and set the tailpiece aside.



## Install the fine tuner

The fine tuner installs from underneath the tailpiece. It should be tight. If for any reason the fine tuner is touching the fiddle top, it will need to be inset up into the tailpiece by chiseling a pocket for it.



## Install the chinrest

The bracket spans the notched area of the chinrest that fits over the tailpiece. Set the chinrest over the tailpiece with clearance on both sides. Find and mark its center, then locate the bracket holes equally from center and drill them with a 1/8" bit. Disassemble the metal bracket and thread the 'L-shaped pieces into the holes (they will cut their own threads). You may want to use a small amount of glue so that they don't come loose.

The chinrest bracket has two turnbuckles that work as ad-



justing bars. To tighten or loosen the bracket, rotate both turnbuckles the same number of turns.

Glue the cork to the bottom of the chinrest and onto the metal bracket where it contacts the fiddle body. Double-stick tape will keep the cork in place, but a glue such as "Goop" is more permanent.

Attach the chinrest to the fiddle. The holes in the turnbuckles allow you to tighten them with a thin tool.



## String the fiddle

Before stringing, put a little graphite into the string slots at the nut by rubbing pencil lead in them.

Protect the top by placing a cloth under the tailpiece, then install the tailpiece. Insert the strings into the tailpiece and run them up to the pegbox, installing them loosely before placing the bridge.

Push approximately 1/4" (6mm) of string through each peg hole and wind it once or twice onto the side away from the peg knob. Continue winding, crossing over the hole, toward the peg knob.

Set the bridge in position, locating the strings over your pencil marks for string spacing. Measure the string spacing again to check for accuracy. Outside strings are 1-5/16" (33.5mm) apart, with equally spaced strings between. Cut notches for the strings with a sharp knife and smooth the edges of these notches with a file or sandpaper.

String to pitch, recheck the bridge alignment, and you're ready to play your fiddle!

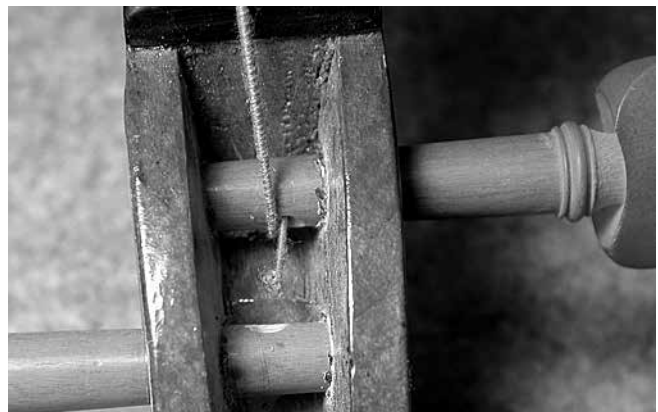

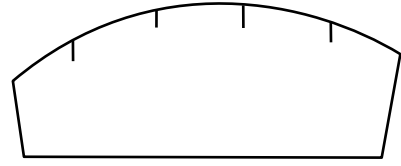

**Bridge Template**  
(see page 14)

**StewMac**<sup>®</sup>  
tools + ideas for guitarmaking

21 N. Shafer St • Athens, Ohio 45701 • USA  
USA & Canada call toll-free: 800-848-2273  
9am-6pm weekdays Eastern time

**[stewmac.com](http://stewmac.com)**

i-5342  
05/17